

## CHAPTER 47. MISCELLANEOUS PROVISIONS

Subchap.	Sec.
<b>A. BEDDING AND UPHOLSTERY .....</b>	<b>47.1</b>
<b>B. CEREAL MILLS, MALT HOUSES AND GRAIN ELEVATORS ....</b>	<b>47.51</b>
<b>C. DRY COLOR INDUSTRY .....</b>	<b>47.81</b>
<b>D. FACILITIES FOR HANDICAPPED .....</b>	<b>47.111</b>
<b>E. FOUNDRIES .....</b>	<b>47.151</b>
<b>F. PRINTING AND RELATED INDUSTRIES .....</b>	<b>47.191</b>
<b>G. RAILINGS, TOEBOARDS, OPEN-SIDED FLOORS, PLATFORMS AND RUNWAYS .....</b>	<b>47.221</b>
<b>H. STUFFED TOYS .....</b>	<b>47.311</b>
<b>I. TEXTILE INDUSTRIES .....</b>	<b>47.341</b>
<b>J. WINDOW CLEANING .....</b>	<b>47.371</b>
<b>K. SAFETY GLAZING MATERIAL .....</b>	<b>47.391</b>

### Subchapter A. BEDDING AND UPHOLSTERY

#### GENERAL PROVISIONS

Sec.	
47.1.	Definitions and use of terms.
47.2.	Applicability.
47.3.	Penalty.

#### ADMINISTRATION

47.11.	Tags and stamps.
47.12.	Registration.
47.13.	Removal from sale.
47.14.	Cleanliness.

#### LABELING

47.21.	Terminology for fillings.
47.22.	Specifications for tags.
47.23.	New and secondhand.
47.24.	Mixtures.
47.25.	Shoddy material.
47.26.	Hair.
47.27.	Sterilization.
47.28.	Permits and records.
47.29.	Renovation.

**ILLUSTRATED TAGS**

- 47.31. Illustrations.  
47.32. Uniform registry number.

**Authority**

The provisions of this Subchapter A issued under act of June 14, 1923 (P. L. 802, No. 314 Repealed by act of May 27, 1937 (P. L. 926, No. 249) (35 P. S. §§ 972—984), unless otherwise noted.

**Source**

The provisions of this Subchapter A adopted February 13, 1934; amended through February 28, 1968, unless otherwise noted.

**GENERAL PROVISIONS****§ 47.1. Definitions and use of terms.**

The following words and terms, when used in this subchapter, have the following meanings, unless the context clearly indicates otherwise, and shall conform to the labeling requirements indicated:

*Acetate fibers* or *cellulose acetate*—Manmade fibers, monofilaments and continuous filament yarns composed of acetylated cellulose with or without lesser amounts of nonfiber forming material.

*Acrylic fibers* or *polyacrylic fibers*—Manmade fibers made from any long chain polymers or copolymers which contain 85% or more of acrylonitrile and which are formed into a filament.

*Arolac, azlon, or casein protein base fibers*—Manmade fibers and filaments made from modified proteins or derivatives of proteins with or without lesser amounts of nonfiber forming material. The term azlon shall be used for labeling purposes regardless of the source of the protein.

*Bulk filling materials*—Bulk materials intended for use in mattresses, pillows, bolsters, feather beds and other filled bedding of any description. The term applies to cushions and all types of upholstered furniture, except cotton rolls, shredded synthetic foam and other filling materials which are sold at retail to be used and consumed in the home of the purchaser for his personal use.

*Cardboard, fiberboard* or *corrugated cardboard*—Sheets of material composed of paper, wood pulp or other materials with or without resin bonding and labeled with their appropriate name.

*Cattail plant fibers*—The fibers from the cattail plant, Apacynaceae Typhaceae. The material shall be labeled cattail fibers.

*Cellulose fiber*—The fibers obtained from wood pulp and compressed into pads. The label designation shall be cellulose fiber pad.

*Cemented shredded latex foam rubber*—Shredded latex foam rubber which has been cemented together.

*Cemented shredded sponge rubber*—Shredded sponge rubber which has been cemented together.

*Cemented shredded synthetic foam*—Shredded synthetic foam which has been cemented together.

*Coconut husk fiber* or *coconut coir*—The fibrous material obtained from the husks or outer shell of the coconut. Either term may be used on the tag.

*Colored*—A material which has been artificially dyed or colored.

*Comfortable*—Any cover, quilt or quilted article made of any material and stuffed or filled with any of the filling materials defined in this section.

*Cotton*—This term shall not be used by itself.

*Cotton felt* or *blended cotton felt*—Felt made from staple cotton, cotton lint-ers, cotton wastes or mixtures of any of those. The label designation shall be cotton felt or blended cotton felt.

*Cotton linters*—The fibrous growth removed from the cotton seed subse-quent to the process of ginning. The term cotton linters may be used on the tag but the term linters alone shall not be used.

*Cotton waste*—Cotton material recovered from various machine operations used in the manufacture of cotton yarn other than cotton itself. When unfelted this material shall be designated on the tag as cotton waste.

*Creped cellulose fiber*—The material formed of layers of compressed and creped cellulose fiber.

*Crushed feathers*—Feathers which have been processed by a curling, crush- ing or chopping machine which has changed the original form of the feathers without removing the quill. The term also includes all of the material compo- nents resulting from this processing. The material or percentage thereof shall be designated on the label as “crushed” and shall be followed by the designa- tion of “waterfowl feathers,” “goose feathers,” “duck feathers,” “chicken feathers,” “turkey feathers” and so forth. When the species of the crushed waterfowl feathers or crushed landfowl feathers or a percentage thereof is des- ignated on the label, a minimum of 80% of the crushed waterfowl feathers or crushed landfowl feathers or a percentage thereof so designated must be of that species.

*Curled hair*—This term shall apply when any hair has been put through a curling process. The appropriate designation as to origin shall appear on the label along with this term.

*Cushion*—Any bag or case, transparent or opaque, and stuffed or filled with any of the materials defined in this section, to be used for resting, reclining or sleeping purposes. This term includes any preformed article made of materials defined in this section and used for reclining, resting, or sitting purposes.

*Disinfection*—The direct application of chemical or physical means to kill pathogenic agents.

*Down*—The soft undercoat of water fowl consisting of the light fluffy fila- ment growing from one quill point but without any quill shaft. The species of

the down or a percentage thereof may be designated on the label. When the species of the down or a percentage thereof is designated on the label a minimum of 80% of the down or percentage thereof so designated must be of that species. An article labeled down or a percentage thereof shall contain a minimum of 80% of down, plumules and down fiber so designated.

*Excelsior*—The fine shredded thread or ribbon-like fiber of wood. This term does not include waste products such as sawdust, shavings or similar materials. The term wood wool is prohibited and the label designation shall be excelsior.

*Feather fiber*—The detached barbs of feathers which are not joined or attached to each other.

*Feathers*—The terms “waterfowl feathers,” “landfowl feathers,” “goose feathers,” “duck feathers,” “chicken feathers,” “turkey feathers” and so forth, shall mean the feathers of the designated fowl which are whole in physical structure with the natural form and curvature originally found in the feathers. The species of the waterfowl feathers or percentage thereof, goose or duck, may be designated on the label. The species of the landfowl feathers or percentage thereof, chicken or turkey, shall be designated on the label. When the species of the waterfowl or landfowl feathers or percentage thereof is designated on the label, a minimum of 80% of the waterfowl feathers or landfowl feathers or a percentage thereof so designated must be of that species. Feathers, crushed feathers or down mixtures shall not be represented to contain a certain percentage of feathers, crushed feathers or down unless it in fact contains the stated percentage with due regard to the tolerances in the definitions of “down,” “feathers” and “crushed feathers.”

*Felt*—Any material which has been carded into layers or sheets by a garnetting or felting machine. This term shall not be used by itself but in conjunction with the name of the materials from which it is made. This term does not include felt scraps or repicked felt.

*Felted mixtures*—Felt made from other than reprocessed fibers and containing the name and percentage of the fibers present, or made from reprocessed fibers containing the names and percentages of fibers present and labeled as felt made from reprocessed fibers. A tolerance of 10% shall be allowed.

*Foam*—A polymerized material consisting of a mass of thin-walled cells produced chemically or physically. This term shall be placed on the tag along with the name of the organic base from which it is made.

*Garnetted clippings*—Any new material which has been made into fabric and subsequently cut up, torn up, broken up, or ground up and which has been run through a garnetting machine and processed to a fibrous state so as to contain not more than 10% yarn or 2.0% fabric. The label designation shall be garnetted clippings.

*Glass fiber*—Fibers made of spun glass. This term shall appear on the tag.

*Hair*—The coarse, filamentous, epidermal outgrowth of animals such as horses, cattle, hogs and goats. This term shall not be used by itself but in conjunction with its particular source as follows:

- (i) *Body hair*—The short soft hair removed from the bodies of animals.
- (ii) *Cattle hair*—The hair from the tails of cattle.
- (iii) *Goat hair*—The hair from any species.
- (iv) *Hog hair*—The bristles and body hair of swine.
- (v) *Horse hair*—The hair of the manes or tails of horses.

*Hair and fiber blends*—The use of filling material of any origin in a mixture with hair. The kind and percentage by weight of each component of the mixture shall be designated on the label, and a tolerance of 10% shall be allowed.

*Hair blends*—The use of two different origins of hair in a blend or mixture. The kind and percentage by weight of each shall be stated on the label, and a tolerance of 10% shall be allowed.

*Hair pad*—Hair which is interwoven or punched on burlap or any other woven material or otherwise fabricated into a pad. Percentages of component materials shall reflect the hair and fiber content only.

*Hay*—Grass, properly cured, dried and free from dust, dirt, burrs, sticks or other objectionable material. This term shall be designated on the tag.

*Jute*—The fiber obtained from various species of corchorus plants.

*Jute pad*—A pad made of jute fibers.

*Jute waste*—The byproduct of rope or cordage, reclaimed rope ends or other fabricated material which have not previously been used for bailing or other purposes.

*Kapok*—The fibrous growth contained in the pod of the Kapok tree, genus *Ceiba Pentenda*. This term shall be designated on the tag, and the use of the term silk floss is prohibited.

*Latex foam rubber*—Natural or synthetic rubber latex which has been converted from a liquid state to a stable foamy mass and molded or otherwise assembled into suitable shapes for commercial use.

*Mattress*—Any quilted pad, mattress, mattress pad, crib pad, mattress protector, bunk quilt or box spring stuffed or filled with any of the filling materials defined in this section, to be used on a couch or other bed for sleeping or reclining purposes.

*Milkweed*—The fibrous growth attached to the seed within the pod of the milkweed plant, genus *Asclepias*.

*Moss*—The material derived from the epiphyte *Tillandsia Useoides*.

*New*—Any material which has not been previously used for any purpose including by-products produced in the manufacture of new textile materials or fabrics and material reclaimed from new fabrics.

*Nylon fibers*—anmade fibers made from any long synthetic polymeric amide which has recurring amide groups as an integral part of the main polymer chain and which is formed into a filament. This term or the term polyamide fiber may be used on the tag.

*Palm fiber*—The fibrous material obtained from the leaf of the palm, palmetto or palmyra tree.

*Person*—Persons, partnerships, companies, corporations or associations.

*Pillow, bolster, feather bed or sleeping bags*—Any bag, case or covering made of any material, transparent or opaque, and stuffed or filled with any of the filling materials defined in this section to be used on a bed, couch, divan, sofa, lounge or other article of furniture for sleeping or reclining purposes.

*Polyester fibers*—Manmade fibers made from a long chain synthetic polymer which contains 85% or more of the polymeric ester produced from the reaction of terephthalic acid and ethylene glycol or other dyhydric alcohols and dicarboxylic acids or produced from hydroxy acids and which is formed into a filament. This term shall be used on the tag.

*Polyethylene fibers*—Manmade fibers made from long chain polymers of ethylene and made into a filament. This term shall be used on the tag.

*Polyurethane fibers*—Manmade fibers made from the copolymerization of diisocyanates and alcohols of diisocyanates and polyesters and formed into filaments. This term shall be used on the tag.

*Polyvinyl fibers*—Manmade fibers made from copolymerization of vinyl chloride and vinyl acetate, vinyl chloride and acrylonitrile, after chlorinated polyvinyl chloride and copolymers of vinylidene chloride and other monomers and made into filaments. This term shall be used on the tag.

*Quill feathers*—The wing and tail feathers of any fowl. This term shall be designated on the tag.

*Rayon*—anmade fibers, monofilaments and continuous filament yarns composed of regenerated cellulose, with or without lesser amounts of nonfiber-forming materials. The terms cellulose or rayon fibers may be used on the tag.

*Redwood bark fibers*—The fibers obtained from the bark of the California Redwood tree, genus *Sequoia Sempervirens*.

*Reprocessed fibers*—Fibers reclaimed from any spun, knitted or woven product which is new. This term applies equally to fibers reclaimed from garnetted clippings, yarns or nappers. The names of the reprocessed fibers shall be set forth on the tag and the percentages of each given if more than one fiber is present.

*Reprocessed jute*—Jute fibers reclaimed from unused fabric, cordage or other similar material. This term shall be designated on the tag.

*Resin treated cotton felt*—Cotton impregnated with vinyl or other resins.

*Rubberized hair or rubberized curled hair*—Any hair treated with natural or synthetic latex. When hair is rubberized, the label designation shall be rubberized hair, or if curled, rubberized curled hair, with the appropriate designation indicating its origin.

*Rubberized hair pieces*—Trimblings and pieces of rubberized hair of indefinite size. The material shall be designated on the label as rubberized hair pieces or rubberized curled hair pieces, whichever term is applicable. When shredded, this material shall be labeled shredded rubberized hair. The term curled shall not be used.

*Sea grass*—Any material obtained from maritime plants or seaweeds. This term shall appear on the tag.

*Secondhand*—Any materials previously used for any purpose. Manufacturing process shall not constitute prior use.

*Shredded clippings*—Any new fabric made from new materials which has been subsequently cut up, ground up, torn up or broken up and which contains more than 10% yarn or 2% fabric. This term shall be designated on the label.

*Shredded latex foam rubber*—Latex foam rubber which has been subjected to a shredding process.

*Shredded sponge rubber*—Sponge rubber which has been subjected to a shredding process.

*Shredded synthetic foam*—Synthetic foams which have been subjected to a shredding process.

*Shoddy*—Any material made from secondhand rags, clothing, yarn, fabric, clippings or nappings by a process of grinding, tearing, or breaking up. This material shall be sterilized. A yellow label shall be used with this designation on all secondhand material consisting of shoddy.

*Silk waste*—The byproducts recovered from various machine operations necessary in the manufacture of threads of natural silk. This term shall appear on the tag.

*Sisal*—The fiber obtained from the Agave plant. This term applies only to new material. If the material is made of waste or reclaimed fibers, the term, “reprocessed sisal fibers,” shall be used on the tag.

*Sisal shoddy*—Reclaimed used cordage or other sisal material which has been fabricated and used for baling or other purposes and which shall be sterilized before use.

*Sponge rubber*—Natural or synthetic solid rubber expanded into a cellular foam and molded or otherwise assembled into suitable shapes for commercial use.

*Staple cotton*—The fibrous growth removed from the cotton seed by ginning. This term may be used on the tag.

*Starch fibers*—Fibers made from long chains of amylose acetate units or regenerated amylose. This term shall be used on the tag.

*Steel wool*—Fibrous material made from very fine steel wire. Either this term or the term steel fiber may appear on the tag.

*Sterilization*—Any process which destroys bacteria—micro-organisms—not necessarily bacterial spores.

*Stripped feathers*—The barbs of feathers stripped by any process from the quill shaft but not separated into feather fiber.

*Straw*—The stalk or stem of grain such as wheat, rye, oats, rice, and the like after threshing. This term shall be designated on the tag. The kind of straw need not be designated but, if so indicated, shall be a true statement. The straw shall be free from chaff, beards, bristles, husks, glumes, dirt or other extraneous matter.

*Synthetic fibers*—Any other synthetic fiber not defined in this section.

*Synthetic foam*—Material made or synthetic products other than synthetic rubber and produced in a resilient foam-like state. This term shall not be used by itself. The label designation shall include terms describing the recurring units or groups of the polymerized product. For example, the foam derived from polyesters and diisocyanate shall be termed polyurethane foam.

*Tampico tula*—The fibers from the leaves of plants such as *Agave Iophantha* or *Hesperaloe Funifera*. The term “tampico” shall be used on the tag, and if curled, the term “curled tampico” may be used.

*Tanners wool*—The growth of wool removed from tanned sheep skins. This term shall be designated on the tag and classed as a new material.

*Tow*—The fibrous coarse straw-like part of a plant recovered as a byproduct in securing commercial fibers and shall be further designated by the plant origin.

*Upholstered furniture*—Any article of furniture stuffed or filled with any of the filling materials defined in this section, to be used for sitting, resting or reclining purposes.

*Wood fiber*—Wood comminuted or reduced to a splintered or fragment piece of finer texture than excelsior.

*Wool blend*—The byproducts recovered from the various machine operations necessary in the manufacture of wool yarn or the byproduct of the tanned sheep hide industry, except tanners’ wool. This term includes wool noils and may be used on the tag.

*Wool or virgin wool*—Fleece of sheep or lamb scoured or scoured and carbonized and free from kemp and vegetable matter. This term shall not apply to the byproduct of any process of manufacture or sustained prior use. Either term may be used on the tag.

#### Source

The provisions of this § 47.1 amended September 17, 1976, 6 Pa.B. 2278. Immediately preceding text appears at serial pages (9177) to (9183).



**Cross References**

This section cited in 34 Pa. Code § 47.21 (relating to terminology for fillings); and 34 Pa. Code § 47.26 (relating to hair).

**§ 47.2. Applicability.**

(a) This subchapter applies to the manufacture, repair, and renovation of all mattresses, pillows, bolsters, feather beds, comforters, all types of upholstered furniture, and other filled bedding of any description which are intended for sale, lease, or auction or which are sold, leased or auctioned within this Commonwealth.

(b) This subchapter applies to all manufacturing or mercantile establishments, both wholesale and retail, when these bedding and upholstered articles are in their possession for the purposes stated in subsection (a), and it places the responsibility of complying with this subchapter upon the vendor, lessor or other person having such article or material in his possession.

**§ 47.3. Penalty.**

Any person who violates this subchapter or any regulations of the Department or who interferes with the Department or its duly authorized representative in the enforcement of these provisions or regulations shall, upon conviction, be punished in accordance with section 12 of act of May 27, 1937 (P. L. 926, No. 249) (35 P. S. § 983).

**ADMINISTRATION****§ 47.11. Tags and stamps.**

(a) Each new and secondhand article of upholstered furniture and each mattress, pillow, bolster, feather bed, comfortable, cushion and bulk filling material shall be tagged and stamped in accordance with this subchapter. Each manufacturer, upholsterer, secondhand dealer, renovator and auctioneer shall furnish his own labels.

(b) Tags shall be so located that the information contained on them is visible. When possible, they shall be securely sewed onto the pillows, mattresses or other material. They shall be securely attached by tacking or pasting.

(c) Every piece of upholstered furniture having one or more cushions shall have one tag when the cushions are a necessary part of that piece. This tag shall contain a statement of the filling materials used in the furniture as well as that used in the cushions. If extra cushions are provided each cushion shall have a separate tag.

(d) Separate tags shall be attached to each bundle, bale, piece, box, roll, container or other package of filling material composed of separable parts when sold, offered for sale, or delivered for use within this Commonwealth.

(e) On each tag shall be affixed an adhesive stamp issued by the Department. The stamp shall be affixed to the front of the tag but it shall not interfere with the statement of filling materials. The stamps shall always be visible.

(f) Adhesive stamps shall be procured from the Department in lots of not less than 1,000 and in multiples of a thousand at the rate of \$15 per thousand.

**§ 47.12. Registration.**

Each manufacturer, upholsterer, secondhand dealer, renovator, upholstery or mattress supplier, and auctioneer shall be registered by the Department and given a registry number. Application shall be made on forms provided by the Department.

**§ 47.13. Removal from sale.**

The Department may remove from sale any article which does not comply with this subchapter. When the articles are removed from sale they shall be tagged with a form furnished by the Department, showing the reason why the article has been withdrawn from sale. These tags shall be removed only by an authorized representative of the Department.

**§ 47.14. Cleanliness.**

(a) All filling material shall be free from acid, oil and dirt before it is used in manufactured products.

(b) The Department shall declare unfit for sale, lease or auction any article containing filling material found by laboratory analysis to be unclean or unsanitary.

## LABELING

**§ 47.21. Terminology for fillings.**

The wording on the tag describing the filling material shall employ only the terms covered by § 47.1 (relating to definitions and use of terms) except that when filling material for which there is no definition used, the tags shall be labeled with the term indicating the material, if it has been accepted by the Department. When springs, spring coverings, burlap, sisal pads, and other similar material are used in addition to the filling materials in the manufacture of mattresses, upholstered furniture and other similar articles these facts shall be so stated on the tags. No trade, superfluous or substitute terms may be used.

**§ 47.22. Specifications for tags.**

(a) Tags shall be of good grade cloth which does not flake when abraded. Paper faced tags shall not be used.

(b) Vinyl tags may be approved when a heat-sealing process is used in the fabrication of vinyl covered articles.

(c) Tags shall not be less than 6 inches in area.

(d) Only the statement required by this subchapter shall appear on the tag. No advertisement or superfluous wordings are permitted. All matters may be placed on another tag and attached to the article in a manner so that it does not interfere with or contradict the statements on it. The official tag shall not be defaced in any manner.

(e) The kind of filling material used shall be stamped or printed on the tag in bold face type not less than 1/8 inch in height.

(f) Notwithstanding anything to the contrary contained in this section, labels on the bottom of slip seat chairs, vanity benches, padded stools and like articles having a smooth bottom, may be of cardboard printed on a white background.

**§ 47.23. New and secondhand.**

(a) The word “new” shall precede the statement of filling material if it is new. The word “secondhand” shall precede the statement of filling material if the filling material had prior use. The words “new” or “secondhand” shall appear on every tag.

(b) Each secondhand article covered by this subchapter including upholstered furniture, containing secondhand material or a portion of the material, shall bear securely attached to it and plainly visible a substantial yellow cloth tag upon which shall be indelibly stamped or printed, in the English language, a statement showing the kind of materials used in filling the article, with approximate percentages when mixed, and shall state whether sterilized and disinfected, with the permit or certificate number of the person or firm who performed such work.

(c) A secondhand framework to which is attached new upholstering material shall bear a yellow tag stating that such article consists of a secondhand frame of wood, iron or steel and the kind of filling materials used.

(d) The use of secondhand materials previously used in any article covered by this subchapter is prohibited in the manufacture of any article covered by this subchapter other than an article returned to its original owner. If the material used in new articles is secondhand, but not prohibited for use, the tag shall show both that the material has been sterilized and disinfected and the permit number of the person or firm doing the sterilization.

**§ 47.24. Mixtures.**

(a) Mixtures of filling material shall show the exact percentage by weight of each labeled ingredient of the mixture. The following shall serve as an example of the possible combinations of mixture and method of labeling for different materials:

- (1) All new materials—
  - 20% goose down
  - 60% goose feathers
  - 20% chicken feathers.

- (2) 50% new curled horse tail hair  
50% new curled hog hair.
- (3) 80% new kapok  
20% new cotton linters.
- (4) All secondhand materials—  
20% cotton linter felt  
80% cotton linters.

(b) Feather or down mixtures shall be designated by the name, character, and percentage by weight of each material used or the entire mixture shall be designated by the name of the lowest grade of material used. A tolerance of 10% shall be allowed.

(c) Each article in which feathers or down are used, whether new or secondhand, shall be labeled to show both that the feathers or down have been sterilized and disinfected and the permit number of the person or firm doing the sterilization.

#### § 47.25. Shoddy material.

Each article in which shoddy material is used shall be labeled to show the following:

- (1) That it has been sterilized and disinfected.
- (2) The permit number of the person or firm doing the sterilization.
- (3) Its sources, such as the following:
  - (i) Shoddy from reworked wool material.
  - (ii) Shoddy from reworked rayon material.
  - (iii) Shoddy from reworked cotton material.
  - (iv) Shoddy from reworked secondhand clothing (materials to be stated).
  - (v) Shoddy, jute from secondhand burlap bagging.

#### § 47.26. Hair.

Hair shall not be labeled curled unless it has been subjected to a curling process as set forth in § 47.1 (relating to definitions and use of terms). Only horse hair, cattle tail hair and hog hair may be so labeled. Each article containing hair shall bear a tag indicating that the hair has been sterilized and disinfected by an approved process and the permit number of the person or firm doing the sterilizing. Hair cloth clippings shall not be described as horse hair.

#### § 47.27. Sterilization.

(a) *General.* All feathers, down, wool, hair and shoddy shall be sterilized and disinfected before being used as filling material.

(b) *Secondhand articles.* All secondhand mattresses, pillows, bolsters, feather beds, comfortables, cushions and upholstered furniture shall be sterilized and disinfected before being resold. The filling material of such secondhand articles shall not again be used as filling material until after it has been sterilized. All

secondhand filling material used in the making or renovating of upholstered furniture shall be sterilized and disinfected before being used.

(c) *Methods.* The following are approved methods of sterilization:

(1) *Chemical gases.* All material to be sterilized by this method shall be treated with formaldehyde in a moist atmosphere for a period of at least ten hours. Formaldehyde gas shall be generated from the use of one pint of formaldehyde solution (37%) to each 1,000 cubic feet of air space or through the use of any commercial fumigators which generate an equivalent quantity of gas. The moist atmosphere shall be produced by thorough sprinkling of the floor of the room with warm water just prior to fumigation. When the sterilizing vault is located within a building where workmen are employed, provision shall be made to exhaust the gases directly to the outside air. Both inlet and exhaust connections shall be equipped with gastight shutoff valves which can be operated from the outside of the vault. The vault door shall be kept locked during the process of sterilization. The safest and most convenient way to release the gas from the formaldehyde solution is to add to the solution 1/2 the amount of potassium permanganate. This boils the solution and releases the gas. To avoid boiling over, the mixing should be done in a large pail. Any of the commercial fumigators which use formaldehyde of the proper quantity and quality will be acceptable when evidence is given that the gas-generating power of the fumigator is equivalent of gas generated from one pint of formaldehyde solution (37%) to each 1,000 cubic feet of space.

(2) *Steam.* Sterilization by the use of steam shall conform to the following:

(i) All materials to be sterilized shall be subjected to treatment by steam under a pressure of 15 pounds maintained for 30 minutes or a pressure of 20 pounds maintained for 20 minutes.

(ii) As an alternate method, two applications of streaming steam, maintained for a period of one hour each, applied at intervals of not less than six nor more than 24 hours, may be used.

(iii) A gauge for registering steam pressure, visible from the outside of the room, shall be provided when steam under pressure is used, and valved outlets shall be provided near the bottom and the top of the room when streaming steam is employed.

(3) *Heat.* A temperature of 235°F held for a period of 2 hours, within a closed container is considered satisfactory for proper sterilization. This method is not recommended for furniture.

(4) *Washing and drying.* Feather pillows will be considered as having been sterilized when the feathers and ticking are kept intact without opening, and washed by a commercial laundry method with subsequent drying to remove moisture. Hair mattresses will be considered as having been sterilized when the hair is removed from the ticking and washed by a commercial laundry method and subsequently dried to remove all moisture, and when the ticking is washed and subsequently dried.

(5) *Spray.* Second-hand articles of bedding or upholstered furniture exposed for sale, lease or auction or delivered for purposes of reupholstering shall be considered as disinfected under the requirements of this chapter when the following process is used:

(i) A separate room, well ventilated to the outside, either naturally or mechanically, shall be provided and isolated from other parts of the establishment. The material or article shall be thoroughly sprayed over all surfaces and in all crevices and corners, including the frame of articles being renovated. A continuous action pressure sprayer shall be used applying a germicidal solution with insecticide additive, approved by the Industrial Board; which application shall be in accordance with the manufacturer's specifications.

(ii) Such disinfected articles shall not be removed from the said isolated room prior to a 30-minute interval after the treatment. The spraying operator is required to use an approved type mask to prevent inhalation of chemicals.

(6) *Other method.* Any other method approved by the Board.

#### Source

The provisions of this § 47.27 amended June 2, 1972, 2 Pa.B. 970. Immediately preceding text appears at serial pages (9189) to (9190).

### § 47.28. Permits and records.

(a) A permit shall be issued by the Department to all persons engaged in sterilizing.

(b) An auctioneer shall fill out a sterilization form furnished by the Department immediately after sterilization and disinfection is completed and mail it to the Department, Division of Bedding and Upholstery.

(c) The Department may upon application issue a certificate authorizing an auctioneer to sterilize certain secondhand articles prior to public sale.

(d) All persons sterilizing articles of bedding, upholstered furniture and all other similar articles shall keep an accurate record of all sterilization work. This record shall include the name of the person for whom the articles were sterilized, the type of articles sterilized, the number of articles sterilized and the date of sterilization. This record shall be available for inspection and examination on demand.

### § 47.29. Renovation.

(a) All renovated articles shall be sterilized by a process registered and approved by the Department before returning the article to the owner.

(b) Materials or articles for fumigation or renovation from institutions such as nursing homes, hospitals, homes for the aged or infirmed, state or private, shall be fumigated or sterilized by chemicals, gas, or live steam. Mechanical renovators may be used to renovate bedding articles from private homes only.

(c) Renovating machines which depend upon ultraviolet ray or ozone generating devices for their disinfecting action may not be used to renovate articles or materials used in hospitals by patients suffering from communicable diseases.

**ILLUSTRATED TAGS**

**§ 47.31. Illustrations.**

The following illustrated tags are applicable to various articles and materials and comply with the provisions of the law and this subchapter relating to labeling. If these provisions are followed, and approved stock is used, proofs need not be submitted but if any departure from the illustrated tags is contemplated two proofs shall be submitted before the tags are printed:

(1) *Number 1.* The white tag for new bulk filling materials required to be sterilized, such as material derived from animal or fowl and for articles containing these types of materials, shall be as follows:

UNDER PENALTY OF LAW  
THIS TAG MAY NOT BE REMOVED  
EXCEPT BY THE CONSUMER

**ALL NEW MATERIAL**  
CONSISTING OF

REG. No. PA.	PER No.
	Certification is made by the manufacturer that the materials in this article are described in accordance with law.  <b>CONTENTS STERILIZED</b>



(2) *Number 2.* The white tag for new bulk filling materials not required to be sterilized, such as vegetable fibers, rubber synthetic fibers and articles containing these types of materials, shall be as follows:

UNDER PENALTY OF LAW  
THIS TAG MAY NOT BE REMOVED  
EXCEPT BY THE CONSUMER

ALL NEW FILLING MATERIAL  
CONSISTING OF

Reg. No. Pa.	
	Certification is made by the manufacturer that the materials in this article are described in accordance with law.



(3) *Number 3.* The yellow tag for articles of secondhand nature and secondhand bulk filling materials shall be as follows:

UNDER PENALTY OF LAW  
THIS TAG MAY NOT BE REMOVED  
EXCEPT BY THE CONSUMER

ALL SECOND-HAND MATERIAL

REG. No. PA.	PER No. PA.
	<b>CONTENTS DISINFECTED</b>  Certification is made that the materials in this article are described in accordance with law.



(4) *Number 4.* The yellow tag for renovated articles to be returned to the owner shall be as follows:



UNDER PENALTY OF LAW  
THIS TAG MAY NOT BE REMOVED  
EXCEPT BY THE CONSUMER

This is A RENOVATED Article and Contains the Same Material Received From the Owner to Which Has Been Added:

REG. No. PA.	PER No. PA.
	<b>CONTENTS DISINFECTED</b>
	This article must not be sold, it is the property of and must be returned to:
OWNER.....	
ADDRESS .....	



(5) *Number 5.* The yellow tag for articles to be leased shall be as follows:

UNDER PENALTY OF LAW  
THIS TAG MAY NOT BE REMOVED  
EXCEPT BY THE LESSEE

This is a RENTAL Article and contains the same material received from the manufacturer and has been disinfected as required by law.

REG. No. PA.	PER No. PA.
	<b>CONTENTS DISINFECTED</b>
	This article must not be sold, it is the property of and must be returned to:



§ 47.32. Uniform registry number.

The Commonwealth approves and recognizes the uniform registry number and will accept the registration number issued by another state if the registrant so

desires, and if such registration follows the policy of uniform registration. This policy is intended to benefit the registrant by requiring but one registration to be imprinted on the law labels used, regardless of where the merchandise may be shipped. The registration number shall be preceded by the name of the state, which may be abbreviated, issuing registration number, and if the factory is located in another state than that issuing the registration number, then the name of the state in which the factory is located shall follow the registration number in parenthesis. The Commonwealth will accept the permit number issued by another state if the applicant so desires and if approval is granted and a Commonwealth sterilization or disinfection permit is issued to applicant bearing the number.

### **Subchapter B. CEREAL MILLS, MALT HOUSES AND GRAIN ELEVATORS**

#### **GENERAL PROVISIONS**

- Sec.  
47.51. Scope.  
47.52. Penalty.

#### **SPECIFICATIONS**

- 47.61. Buildings and elevators.  
47.62. Mechanical power transmission apparatus.  
47.63. Fire protection of boilerrooms.  
47.64. General requirements.  
47.65. Waste and foreign substances.  
47.66. Dust.  
47.67. Fire extinguishers.

#### **Authority**

The provisions of this Subchapter B issued under act of June 2, 1913 (P. L. 396, No. 267) (71 P. S. § 1442); and act of May 18, 1937 (P. L. 654, No. 174) (43 P. S. §§ 25-1—25-15), unless otherwise noted.

#### **Source**

The provisions of this Subchapter B adopted April 1, 1917; amended through July 1, 1968, unless otherwise noted.

**GENERAL PROVISIONS****§ 47.51. Scope.**

This Subchapter sets forth rules to safeguard the lives, limbs and health of workers employed in cereal mills, malt houses and grain elevators, and places the responsibility of complying with this subchapter upon both employer and employe.

**§ 47.52. Penalty.**

Any person who violates this subchapter or any regulations of the Department or who interferes with the Department or its duly authorized representative in the enforcement of these provisions or regulations shall be penalized under section 15 of act of May 18, 1937 (P. L. 654, No. 174) (43 P. S. § 25-15).

**SPECIFICATIONS****§ 47.61. Buildings and elevators.**

(a) *Application.* The standards as set out in this subchapter apply to all establishments commonly known as flour, feed, cereal mills and grain elevators, and to malt house elevators where such elevators are specifically referred to.

(b) *Approval.* Plans and specifications for all new mills constructed shall be submitted in duplicate to the Department for inspection, and no new building shall be operated as a mill until approved by the Department.

(c) *Elevator pits.* Pits for elevator boots shall be constructed of cement or its equivalent, and have a clearance of not less than three feet on one side or two on each of two sides of the boots.

(d) *Automatic stops.* Elevators for employes shall have an automatic stop to prevent the passengers from being carried over the top.

**§ 47.62. Mechanical power transmission apparatus.**

(a) *Emergency stops.* Emergency stops are not required in cereal mills, malt houses and grain elevators. The apparatus shall be arranged so that they may be stopped as a whole, as promptly as practicable, and in a manner which meets the approval of the Department.

(b) *Guarding.* The Department may upon written application grant an exception to the requirements as to guarding of individual shafts, pulleys and belts in basements containing only power transmission equipment and machines not operated from the basement, if there are no entrances to the basement from the exterior of the mill and if each entrance to the basement from the mill is equipped with a self-closing door or gate with a sign on it as follows:

**DANGER**  
**RUNNING MACHINERY**  
**KEEP OUT**

(c) *Additional exception.* In basements containing machines operated from the basement, the exception set forth in subsection (a) may be similarly granted for the shafts, pulleys and belts in that part of the basement in which there are no machines if the following conditions exist:

- (1) There are no entrances to the basement from the exterior of the mill.
- (2) A standard railing separates this part from that containing the machine.
- (3) Each entrance to that part of the basement containing no machines has a self-closing door or gate with a sign on it as follows:

**DANGER**  
**RUNNING MACHINERY**  
**KEEP OUT**

(d) *Overhead belts.* Overhead belts with the lower part 7 feet or less from the floor or working platform level may be considered as guarded if located over a machine or other permanent construction, so that it is impossible for any one to pass between them.

**§ 47.63. Fire protection of boilerrooms.**

In all existing mills it is recommended that each interior opening from boilerrooms and enginerooms have, on one side of the wall, an approved automatic self-closing fire door. When the boilerroom is situated in the basement or cellar it is recommended that the walls and ceiling be fireproof and have no opening to the mill proper, except those necessary for the transmission of power, light, heat and water. When steam and exhaust pipes pass through partitions which are not of fireproof construction it is recommended that such pipes be incased in asbestos or other approved fire-resisting casing, or so supported as to allow an air space of 1/2 inch between the pipes and any part of the partition. In any new mills, it is recommended that the boilerroom connect only with the engineroom, and be separated from the engineroom and the mill proper by a fire wall parapeted three feet above the roof, having no openings, except those necessary for the transmission of power, light, heat and water. There shall be one entrance between the boilerroom, and the engineroom, protected with an approved automatic self-closing fire door.

**§ 47.64. General requirements.**

(a) *Artificial lighting.* All buildings shall be constructed to afford ample daylight for all working parts. Artificial lights shall be provided in accordance with

Chapter 27 (relating to lighting) when daylight is not available. In spaces occupied by machinery, or in spaces where dust may collect, open lights are not permitted, except gas lights with hoods, approved by the insurance underwriters. Only standard enclosed tubular lanterns shall be used.

(b) *Belt conveyors.* All belt conveyors for receiving grain shall have at the point of charge, a hood connected with an exhaust fan of sufficient capacity to remove or prevent the escape of all dust arising from the conveyor, and the fan shall be kept in operation when the conveyor is in use, unless another equally effective dust removing system is provided. This requirement shall not apply to the point at which a railroad car hopper discharges onto a belt conveyor.

(c) *Grain garnerers and malt house elevators.* It is recommended that tops of grain garnerers over scales be covered with wood, metal or other impervious material, and the covers be tight fitting to prevent entirely the escape of dust. This recommendation applies to malt house elevators.

(d) *Grain hoppers.* Until grain is thoroughly cleaned, hoppers for weighing shall be provided with tight fitting covers of wood, metal or other material, impervious to dust and with flexible dustproof connections to the bottom of the garner, if there is a garner. This requirement applies only to weighing hoppers located indoors and to malt house elevators.

(e) *Piping.* The piping of all exhaust systems and all ducts shall be kept tight.

#### § 47.65. Waste and foreign substances.

(a) It is recommended that metal cans with self-closing covers be placed on each floor of buildings containing machinery in which to place oiling waste or other combustible material.

(b) Before grain is ground or passes to grinding machines, it is recommended that foreign substances be removed by separators, or proper sieves or magnets.

#### § 47.66. Dust.

(a) Dust or stive rooms shall not be used. A fan discharging dust shall discharge either to the outer air at such points where the dust may not reenter the mill or an adjacent building, or to a dust collector, and the air vent or outlet to every cyclone dust collector shall discharge to the outer air or to another dust collector. All tubular dust collectors, shall be maintained in a proper state of repair to prevent leakage of dust into the room. A fan, which discharges into any dust collector, shall be kept in operation at all times while the machine or machines with which it is connected are in operation. There shall be no direct connection between dust collectors and boiler rooms or incinerators. This requirement applies to malt house elevators.

(b) Mills and all buildings, structures, and elevators used in connection with the operation of mills shall be kept thoroughly clean and free from dust. Dust shall be removed from floors and machinery daily, and all other parts of the mill, including fixtures, bearings, ledges, projections, side walls and ceilings, and all

buildings, structures and elevators, shall be kept free from all accumulation of dust. This requirement also applies to malt house elevators.

**§ 47.67. Fire extinguishers.**

(a) It is recommended that approved 2 1/2 gallon chemical extinguishers be distributed throughout the building in the proportion of not less than one to each 2,500 square feet of floor area, and placed at readily accessible points near the usual working place of workmen. Three pails and 50 gallon cans of water may be considered the equivalent of one 2 1/2 gallon extinguisher.

(b) It is recommended that near each electric motor or other large electric appliance, at least a one quart chemical extinguisher of carbon tetrachloride type should be provided. This recommendation also applies to malt house elevators but not to buildings equipped with an approved sprinkler system.

**Subchapter C. DRY COLOR INDUSTRY**

Sec.	
47.81.	Scope.
47.82.	Place.
47.83.	Employes.
47.84.	Male employes.
47.85.	Habits of employes.
47.86.	Safety standards.
47.87.	Sanitation.
47.88.	Physical examination.
47.89.	Tank processes.
47.90.	Filter pressing and straining.
47.91.	Dry grinding, sieving and packing.
47.92.	Lead poisoning law.
47.93.	Penalty.

**Authority**

The provisions of this Subchapter C issued under act of July 26, 1913 (P. L. 1363, No. 851) (43 P. S. §§ 471—480); and act of May 18, 1937 (P. L. 654, No. 174) (43 P. S. §§ 25-1—25-15), unless otherwise noted.

**Source**

The provisions of this Subchapter C adopted August 1, 1917, amended through July 1, 1968, unless otherwise noted.

**Cross References**

This subchapter cited in 34 Pa. Code § 11.85 (relating to applicable provisions of other regulations).

**GENERAL PROVISIONS****§ 47.81. Scope.**

This subchapter sets forth rules to safeguard the lives, limbs and health of workers in the dry color industry, and places the responsibility of complying with such rules upon both employer and employe.

**§ 47.82. Place.**

(a) Each employer shall, without cost to his employes, provide and maintain workrooms which are adequately lighted and so ventilated and arranged that there is a continuous and sufficient change of air for the protection of his employes who are engaged in any work or process in which is used, in dry form, carbonate of lead, red lead, litharge, orange mineral, basic lead sulphate (sublimed white lead), chromate of lead, arsenate of lead, sugar of lead, fluosilicate of lead, lead nitrate or any other form or compound containing lead in excess of 10% entering into the composition of any dry color or other compound sold as such. All rooms shall have a smooth floor permitting an easy removal of dust by vacuum cleaning, by flushing the floor with water or by sweeping after the floor has been sprinkled with a sufficient quantity of wet sawdust to lay all dust. The walls of the room shall be smooth and it is recommended that they be either painted or whitewashed at frequent intervals permitting an easy removal of dust by vacuum cleaning or by flushing the walls with water. Dry sweeping of the floors and walls is prohibited.

(b) The daily removal of all dust from floors and walls by vacuum cleaning is recommended as the best and most economical method of cleaning.

**Cross References**

This section cited in 34 Pa. Code § 47.84 (relating to male employes); and 34 Pa. Code § 47.88 (relating to physical examination).

**§ 47.83. Employes.**

Persons engaged in occupations involving exposure to lead dusts, lead fumes or lead solutions in any form shall be at least 18 years of age and shall be physically examined at the expense of the employer by a licensed physician at least once every 30 days. Records of the examination shall be kept on file and available to inspectors of the Department.

**Source**

The provisions of this § 47.83 amended June 10, 1977, 7 Pa.B. 1592. Immediately preceding text appears at serial page (9200).

**§ 47.84. Male employes.**

No male employes less than 18 years of age shall engage in any work or process in § 47.82 (relating to place).

**§ 47.85. Habits of employes.**

Since the use of alcoholic liquors and chewing tobacco undermines the health and predisposes to lead poisoning and industrial accidents, it is recommended that the employment of anyone who habitually uses alcoholic liquors or who chews tobacco be discouraged. Employers are urged to exclude the persons from employment in any capacity in the dry color industry.

**§ 47.86. Safety standards.**

(a) *Other provisions.* All power transmission machinery, railings and toe-boards, stationary steam engines, boilers, ladders, fire prevention, elevators and artificial lighting shall conform to the requirements of the appropriate chapter and subchapter of Part I (relating to Department of Labor and Industry).

(b) *Respirators.* When this subchapter requires it, the employer shall provide and renew when necessary, without cost to the employe, at least one reasonably effective respirator for each employe, and the employe shall keep it clean and use it at all times while at work.

(c) *Efficiency.* A respirator shall be considered efficient only when it fits the contour of the face and allows no air to enter the mouth or nose except air which has passed through the respirator. At least three thicknesses of gauze or cheesecloth shall be considered an efficient respirator if the gauze or cheesecloth is thoroughly washed every day.

**§ 47.87. Sanitation.**

(a) *Scope.* This section sets forth sanitary requirements for employes handling dry lead or dry compounds containing lead in excess of 10%.

(b) *Washing facilities.* The employer shall provide washrooms which shall be separate and apart from the workrooms, kept clean and equipped with any of the following:

(1) At least one lavatory basin for every five employes, fitted with waste pipes and two spigots conveying hot and cold water.

(2) Basins placed in troughs fitted with waste pipes and for each basin two spigots conveying hot and cold water, and at least one basin for every five employes.

(3) Troughs of enamel or similar smooth, impervious material, fitted with waste pipes and for every 2 feet of trough length two spigots conveying hot and cold water, and at least 2 feet of trough length for every five employes.

(4) Troughs of enamel or similar smooth, impervious material, fitted with waste pipes without plugs, but with a continuous spray of warm water.

(c) *Nail brushes, towels and soap.* The employer shall furnish nail brushes and soap, and at least three clean fabric towels each week for each employe, or a sufficient number of sanitary paper towels.



(d) *Time allowance.* A time allowance of 10 minutes at the expense of the employer shall be made to each employe for the use of such washrooms before the lunch hour and at the close of each work day.

(e) *Shower bath.* The employer shall provide at least one shower bath for every ten employes. The baths shall be approached by wooden runways, with movable wooden floor gratings, and with hot and cold water controlled within each individual bath. The baths shall be kept clean.

(f) *Use of shower baths.* The employer shall provide at least two clean fabric bath towels per week for each employe. An additional time allowance of ten minutes at the expense of the employer shall be made to each employe for the use of such baths at least twice a week at the close of the work day. It shall be the duty of all employes to use the washing facilities furnished by the employer.

(g) *Urinals.* Urinals and water closets shall be furnished in accordance with the requirements of Chapter 41 (relating to sanitation).

(h) *Locker rooms.* The employer shall provide dressing rooms which shall be adequately heated when necessary and separate from the workrooms and be furnished with a double sanitary locker or two single sanitary lockers for each employe. The room and the lockers shall be kept clean and sanitary. In lieu of lockers, wire baskets for clothes may be provided, which shall be attached to a rope passed through a pulley and pulled up to the ceiling when containing clothing.

(i) *Eating rooms.* The employer shall furnish and keep clean eating rooms with a sufficient number of tables and seats. The eating rooms shall be separate from the workrooms.

(j) *Eating in workrooms.* No employe or other person shall take or be permitted to take any food or drink of any kind into any workroom, nor shall any employe remain or be permitted to remain in any workroom during the time allowed for meals.

(k) *Drinking fountains.* The employer shall provide and maintain either a sufficient number of sanitary drinking fountains readily accessible for the use of all employes, or individual drinking cups.

(l) *Overalls.* The employer shall provide without cost to the employe, at least one pair of overalls and one jumper for each employe, repair and renew such clothing when necessary, and wash them at least once each week.

(m) *Notice.* The employer shall post in a conspicuous place in each workroom, washroom, dressing room, and eating room the following notice:

#### **DANGERS OF LEAD**

Lead is a poison.

With proper care you can handle it with no danger.

If handled carelessly it will almost without fail cause sickness.

This sickness, commonly called lead poisoning, may be only slight or it may be very severe.

It may show itself as headaches, cramps, constipation, loss in weight, paralysis, disease of the heart, blood vessels, or kidneys, insanity, and may cause death.

#### AVOID LEAD POISONING

##### **Keep Lead Dust Out of Your Nose**

Wear a respirator when working in lead dust.

Do no dry sweeping. Clean floors and walls with a vacuum cleaner, wash them with water, or sweep only when dust has been laid with wet sawdust or similar material.

##### **Keep Lead Dust Out of Your Mouth**

Before eating and before leaving work wash hands, arms, and face with soap and warm water, and rinse mouth thoroughly.

Keep fingernails short and clean, scrub hands with a brush, soap, and warm water.

Keep beard and moustache cut short, or better still be clean shaven as it is hard to wash dust from hair.

Bathe often, every day if possible.

Take no food into the workroom; it will gather dust that you will eat later on.

Chew no tobacco while at work; lead is sure to reach your mouth when you handle your tobacco with unwashed hands.

##### **Keep Yourself In Good Health**

Eat a hearty meal before starting work.

Drink plenty of milk.

Use no alcoholic drinks.

Have a good bowel movement every day; take an occasional dose of Epsom or Glauber's salts or other laxative if necessary.

If not feeling well consult your plant doctor or your family physician at once. Every case of lead poisoning can be cured if treated early.

By taking home remedies or by depending on the advice of fellow workers or friends you lose valuable time, causing your sickness to last longer and to be more severe.

Additional copies of this notice, suitable for posting, will be furnished without charge, upon written request to the Department of Labor and Industry, Harrisburg, Pennsylvania. Ask for Form I-117.

#### **§ 47.88. Physical examination.**

(a) *Generally.* The employer shall cause every employe who is exposed to lead dusts, lead fumes or lead solutions, to be physically examined at least once

a month by a licensed physician to ascertain if symptoms of lead poisoning appear in any employe. The employe shall submit himself to the monthly examination, and to examination at other times and places as he may reasonably be requested by the employer, and he shall fully and truly answer all questions in regard to his physical condition asked by the examining physician. These examinations shall be made by a licensed physician, designated and paid by the employer, and shall be made during the working hours. A time allowance at the expense of the employer shall be made to each employe so examined.

(b) *Record.* Each physician making an examination as required by subsection (a) and finding what he believes to be symptoms of lead poisoning, shall enter, in a book kept for that purpose in the office of the employer, a record of such examination, containing the name and address of the employe so examined, the particular work or process in which he is engaged, the date, place, and finding of such examination, and the directions given in each case by the physician. The record shall be open to inspection at all reasonable times by inspectors of the Department.

(c) *Report.* If the examining physician believes that lead poisoning is present, he shall send a report in duplicate within 48 hours to the Department, and a report to the Department of Health. The examining physician shall also, within 48 hours, report the examination and finding in writing to the employer, and upon receipt of the report the employer shall discontinue the employe in any work or processes where he may be exposed to lead dust, lead fumes or lead solutions included in § 47.82 (relating to place).

#### § 47.89. Tank processes.

(a) *Handrails and toeboards.* All tanks shall be protected by handrailings and toeboards in accordance with the requirements of Subchapter G (relating to railings, toeboards, open-sided floors, platforms and runways).

(b) *Gloves and respirators.* Chromates shall only be handled by employes wearing suitable gloves furnished by the employer without charge. When material is handled dry, employes shall wear an efficient respirator furnished by the employer.

(c) *Goggles.* The employer shall provide suitable goggles for all employes handling oil of vitriol, nitric acid, nitrous iron liquor and muriatic acid. All employes shall wear such goggles at all times when handling the acids.

(d) *Caustic soda.* Fused caustic soda may be used in processes where the entire contents of the drum are dissolved without breaking up. When lesser quantities are used, only granulated caustic soda is permitted, and the granulated caustic soda may be handled only by men wearing a suitable type of head covering.

(e) *Paranitraniline.* It is recommended that weighing and dissolving of dry paranitraniline be done under a hood connected with an efficient air exhaust.

Employes engaged in the work shall protect their bodies with suitable clothing, suitable gloves and an efficient respirator furnished by the employer without expense to the employe.

(f) *Nitrous fumes.* All oxidizing tanks for blues within the building which subject employes to the danger of either chlorine or nitrous fumes shall have either tight fitting covers or proper hoods connected with an efficient mechanical air exhaust.

(g) *Nitrous iron liquor.* All tanks for the manufacture of nitrous iron liquor shall be placed in a building or room separate and apart from other workrooms, and all tanks shall be covered with tight fitting covers connected with an efficient air exhaust.

(h) *Lead salts.* All vats in which solutions of soluble lead salts are boiled shall be protected by suitable hoods.

(i) *Lead solutions.* It is recommended that lead solutions be made in large quantities and from either metallic lead or litharge. If litharge is used it shall be dampened.

(j) *Pulp lead.* It is recommended that pulp lead be used instead of dry carbonate of lead whenever possible.

#### § 47.90. Filter pressing and straining.

(a) *Mechanisms.* In the manufacture of parareds the diazotised solution shall be run through double cheesecloth or other filtering medium when going to the precipitating tanks.

(b) *Gloves.* All workers engaged in filter-pressing compounds containing either lead or arsenic shall wear suitable gloves furnished by the employer for their protection.

(c) *Respiration and gloves.* Employes handling dry color cakes containing lead or arsenic shall wear suitable gloves and respirators furnished by the employer and such substances shall not be emptied in the dry room.

(d) *Dry room.* Dry rooms constructed after 1917 shall not require entering by employes to remove their contents.

#### § 47.91. Dry grinding, sieving and packing.

(a) *Exhaust system.* Crushing mills, grinding mills and sieving machines, operating on material in a dry state if containing lead in excess of 10% shall be connected with an efficient air exhaust and dust collecting system, plans for which shall be submitted to and approved by the Department.

(b) *Packing.* Dry packing of material containing lead in excess of 10% or arsenic, shall be carried on by an approved type of packing machine. If material is packed by hand, employes shall wear approved respirators.

(c) *Mixing and shading.* Mixing and shading of dry materials containing lead in excess of 10% or arsenic, shall be performed in a room with mechanical exhaust ventilation, plans for which will be approved by the Department.

**§ 47.92. Lead poisoning law.**

The act of July 26, 1913 (P. L. 1363, No. 851) (43 P. S. §§ 471—480) requires that whenever employes are exposed to lead dust, lead fumes and lead solutions in the manufacture of white lead, red lead, litharge, sugar of lead, arsenic of lead, lead chromate, lead sulphate, lead nitrate and fluosilicate of lead, the employer shall post an abstract of the lead poisoning law. The abstracts are printed in several languages and are available upon application to the Department.

**§ 47.93. Penalty.**

A person who violates this subchapter or regulations of the Department or who interferes with the Department or its authorized representative in the enforcement of these regulations or this subchapter shall be penalized under section 15 of act of May 18, 1937 (P. L. 654, No. 174) (43 P. S. § 25-15).

**Subchapter D. FACILITIES FOR HANDICAPPED****GENERAL PROVISIONS**

Sec.	
47.111.	Scope.
47.112.	Penalty.

**GROUND, BUILDINGS AND FACILITIES**

47.121.	Walks.
47.122.	Parking areas.
47.123.	Ramps.
47.124.	Entrances.
47.125.	Stairs.
47.126.	Floors.
47.127.	Restrooms and plumbing fixtures.
47.128.	Elevators.
47.129.	Controls.
47.130.	Phone booths.
47.131.	Hazards.

**Authority**

The provisions of this Subchapter D issued under act of September 1, 1965 (P. L. 1613, No. 235) (71 P. S. §§ 1455.1—1455.3a), unless otherwise noted.

**Source**

The provisions of this Subchapter D adopted June 20, 1966, unless otherwise noted.

**Cross References**

This subchapter cited in 16 Pa. Code § 44.6 (relating to access); 22 Pa. Code § 31.21 (relating to curricula); and 22 Pa. Code § 31.43 (relating to buildings and equipment).

**GENERAL PROVISIONS****§ 47.111. Scope.**

(a) This subchapter pertains to buildings of assembly, educational institutions and office buildings which are constructed in whole or in part by the use of Commonwealth funds or the funds of an instrumentality of the Commonwealth, and sets forth rules, standards and specifications that apply to those buildings and facilities constructed in this Commonwealth after 1965 except those buildings or facilities for which contracts for the planning or design have been awarded prior to September 1, 1965.

(b) If the existing or designed dimensions are within 5% of the maximum or minimum specified, they shall be deemed to comply with this subchapter.

**Source**

The provisions of this § 47.111 amended July 22, 1971, 1 Pa.B. 1652.

**Cross References**

This section cited in 31 Pa. Code § 243.6 (relating to standards for institutional plan of risk management for hospitals and nursing homes); 31 Pa. Code § 244.3 (relating to standards for institutional plan of risk management for hospitals and nursing homes); and 34 Pa. Code § 47.121 (relating to walks).

**§ 47.112. Penalty.**

A person who violates this subchapter or regulations of the Department or who interferes with the Department or its authorized representative in the enforcement of the regulations and this subchapter shall be penalized under the act of September 1, 1965 (P. L. 1613, No. 235) (71 P. S. §§ 1455.1—1455.3a) and the act of April 27, 1927 (P. L. 465, No. 299) (35 P. S. §§ 1221—1235).

**Cross References**

This section cited in 31 Pa. Code § 243.6 (relating to standards for institutional plan of risk management for hospitals and nursing homes); and 31 Pa. Code § 244.3 (relating to standards for institutional plan of risk management for hospitals and nursing homes).

**GROUND, BUILDINGS AND FACILITIES****§ 47.121. Walks.**

There shall be at least one walk serving each of the buildings as set forth in § 47.111 (relating to scope) conforming to the following specifications:

- (1) Be at least 48 inches wide with a slope no portion of which is steeper than 5%.

(2) Be of a continuing common surface uninterrupted by steps or abrupt changes in grade.

(3) Blend to a common level whenever the walk crosses other walks, driveways or parking lots.

(4) Have a level platform at the building entrance which it serves and the platform shall be at least 5 feet square if a door swings out on to the platform or toward the walk; the platform shall extend at least 1 foot beyond each side of the doorway.

(5) Have a level platform at least 3 feet deep and 5 feet wide if the door does not swing on to the platform or toward the walk; the platform shall extend at least 1 foot beyond each side of the doorway.

#### **Cross References**

This section cited in 31 Pa. Code § 243.6 (relating to standards for institutional plan of risk management for hospitals and nursing homes); and 31 Pa. Code § 244.3 (relating to standards for institutional plan of risk management for hospitals and nursing homes).

### **§ 47.122. Parking areas.**

At least one parking area for handicapped persons shall be made accessible to each building either by placing the parking level at the grade level of the building or by providing ramps to bypass curbs or steps between the parking area and the building. The ramps, when provided, shall be in accordance with this subchapter.

#### **Cross References**

This section cited in 31 Pa. Code § 243.6 (relating to standards for institutional plan of risk management for hospitals and nursing homes); and 31 Pa. Code § 244.3 (relating to standards for institutional plan of risk management for hospitals and nursing homes).

### **§ 47.123. Ramps.**

When ramps are required they shall conform to the following specifications:

(1) Each ramp shall have a slope no greater than 1 foot rise in 12 feet of run or 8.33% grade or 4 degrees and 50 minutes deflection.

(2) Each ramp shall have a handrail on at least one side or preferably on both sides. If the width of the ramp exceeds 84 inches, there shall be an intermediate rail in the ramp. The top of handrails shall be 32 inches above the surface of the ramp and extend one foot beyond the top and bottom of the ramp.

(3) Each ramp shall be at least 32 inches wide (inside clear measurements) and have a nonslip surface.

(4) If a door swings out onto the platform or toward the ramp, such ramp shall be at least 5 feet square. This platform shall be clear of the door frame.

(5) If the door does not swing on to the platform or toward the ramp, this platform shall be at least 3 feet deep and 5 feet wide, and clear of the door frame.

- (6) The bottom of the ramp shall have at least 6 feet level run.
- (7) If the length of the ramp exceeds 30 feet, level platforms shall be provided at 30 foot intervals, and at turns in the ramp. These platforms shall be at least 32 inches wide (in all cases the width of the ramp) by 5 feet long.

**Cross References**

This section cited in 31 Pa. Code § 243.6 (relating to standards for institutional plan of risk management for hospitals and nursing homes); and 31 Pa. Code § 244.3 (relating to standards for institutional plan of risk management for hospitals and nursing homes).

**§ 47.124. Entrances.**

(a) Each building shall have at least one entrance accessible to individuals in wheelchairs. When this building is equipped with elevators, this entrance shall provide access to the elevator either on a level plane or by ramp.

(b) Doors which serve as closures for the entrance shall have a clear opening of not less than 32 inches, be double acting and operable by a single effort. The floor on the inside and outside of each doorway shall be level for a distance of 5 feet on each side of the doorway and shall extend 1 foot beyond each side of the door. Sharp inclines and abrupt changes in level shall be avoided at door sills. If practical, thresholds shall be flush with the floor or otherwise offer little resistance to the operation of a wheel chair.

**Cross References**

This section cited in 31 Pa. Code § 243.6 (relating to standards for institutional plan of risk management for hospitals and nursing homes); and 31 Pa. Code § 244.3 (relating to standards for institutional plan of risk management for hospitals and nursing homes).

**§ 47.125. Stairs.**

Steps in stairs shall be designed whenever practical to lack nosing. This requirement is in addition to the requirements of Chapters 49—59 that no treads may be less than 10 inches. It is recommended that steps, if possible and in conformation with existing step formulas, have risers that do not exceed 7 inches. Stairs shall have handrails 32 inches high measured from the tread at the face of the riser, and at least one handrail which extends at least 18 inches beyond the top step and beyond the bottom step.

**Cross References**

This section cited in 31 Pa. Code § 243.6 (relating to standards for institutional plan of risk management for hospitals and nursing homes); and 31 Pa. Code § 244.3 (relating to standards for institutional plan of risk management for hospitals and nursing homes).

**§ 47.126. Floors.**

Floors, if practical, shall have a nonslip surface. Floors on the same story shall be of a common level throughout or be connected by a ramp in accordance with provisions of this subchapter.



**Cross References**

This section cited in 31 Pa. Code § 243.6 (relating to standards for institutional plan of risk management for hospitals and nursing homes); and 31 Pa. Code § 244.3 (relating to standards for institutional plan of risk management for hospitals and nursing homes).

**§ 47.127. Restrooms and plumbing fixtures.**

(a) On each floor of the building there shall be at least one toilet room for each sex equipped in accordance with the following specifications:

(1) Toilet rooms shall be accessible to and usable by the physically handicapped and shall have space to allow traffic of individuals in wheel chairs.

(2) Toilet rooms shall have at least one toilet stall that meets the following requirements:

(i) Three feet in width.

(ii) At least 4 feet 8 inches, but preferably 5 feet, in depth.

(iii) A door, if doors are used, 32 inches in width that swings out.

(iv) Grab bars or handrails on each side 33 inches in height and parallel to the floor, 1 inch or more on outside diameter with one to 1/2 inch clearance between the rail and the wall and which is securely fastened at the ends and center.

(v) A water closet with the seat 20 inches from the floor.

(3) Toilet stalls shall be furnished for each sex in accordance with the following table:

<i>Number of Persons</i>	<i>Number of Stalls</i>
1—15	1
16—30	2
31—50	3

(4) Toilet stalls shall be provided for each sex in the ratio of at least one for each 25 or less persons.

(5) Toilet rooms shall have either lavatories with narrow aprons, which, when mounted at standard height, are usable by individuals in wheelchairs, or lavatories mounted higher, when particular designs demand, so that they are usable by individuals in wheelchairs.

(6) Mirrors and shelves shall be provided above lavatories at a height as low as practical but no higher than 40 inches above the floor, measured from the top of the shelf and the bottom of the mirror.

(7) Toilet rooms for men shall have either an appropriate number of wall-mounted urinals with the opening of the basin 19 inches from the floor or an appropriate number of floor-mounted urinals that are on a level with the main floor of the toilet room.

(8) Toilet rooms shall have an appropriate number of towel racks, towel dispensers and other dispensers and disposal units mounted no higher than 40 inches from the floor.

(9) An appropriate number of water fountains or other water-dispensing means shall be accessible to and usable by the physically disabled. Water fountains or coolers shall have up-front spouts and controls, and be either hand-operated or hand-and-foot operated.

(b) Toilet rooms may be located one floor above or below the regular place of occupancy of the person or persons for whose use they are provided in those buildings if there are a sufficient number of passenger elevators.

#### **Cross References**

This section cited in 31 Pa. Code § 243.6 (relating to standards for institutional plan of risk management for hospitals and nursing homes); and 31 Pa. Code § 244.3 (relating to standards for institutional plan of risk management for hospitals and nursing homes).

### **§ 47.128. Elevators.**

When elevators are provided at least one designated elevator shall be accessible to and usable by the physically disabled at all levels normally used by the general public. Elevators shall be self-leveling. Doors shall be slow-closing and shall not close if anything is in the opening, the sensing for which shall be done without touching the intervening object. However, in the event of failure of the sensing device a mechanical safety edge may be employed as an additional safety feature. When photoelectric eyes are installed, which shall be a minimum of two in number, they shall be located not less than 6 inches, nor more than 36 inches, above the car threshold. Elevators shall be designed to allow traffic by wheelchairs.

#### **Source**

The provisions of § 47.128 amended July 22, 1971, 1 Pa.B. 1435.

#### **Cross References**

This section cited in 31 Pa. Code § 243.6 (relating to standards for institutional plan of risk management for hospitals and nursing homes); and 31 Pa. Code § 244.3 (relating to standards for institutional plan of risk management for hospitals and nursing homes).

### **§ 47.129. Controls.**

Switches and controls for light, heat, ventilation, windows, draperies, elevators and similar controls of frequent or essential use, shall be placed within the reach of individuals in wheel chairs, and in no occasion at a level of more than 40 inches above the floor.

**Cross References**

This section cited in 31 Pa. Code § 243.6 (relating to standards for institutional plan of risk management for hospitals and nursing homes); and 31 Pa. Code § 244.3 (relating to standards for institutional plan of risk management for hospitals and nursing homes).

**§ 47.130. Phone booths.**

If phone booths are provided in the buildings at least one phone booth shall have a door wide enough to admit a wheel chair and a seat higher than normal.

**Cross References**

This section cited in 31 Pa. Code § 243.6 (relating to standards for institutional plan of risk management for hospitals and nursing homes); and 31 Pa. Code § 244.3 (relating to standards for institutional plan of risk management for hospitals and nursing homes).

**§ 47.131. Hazards.**

(a) Every effort shall be exercised to obviate hazards to individuals with physical disabilities. Lighting in doorways, toilets and areas of similar importance shall be adequate and nonglare.

(b) If practical, electronically-operated doors shall be used in public corridors. The doors shall be of a type approved by the Board.

**Cross References**

This section cited in 31 Pa. Code § 243.6 (relating to standards for institutional plan of risk management for hospitals and nursing homes); and 31 Pa. Code § 244.3 (relating to standards for institutional plan of risk management for hospitals and nursing homes).

**Subchapter E. FOUNDRIES****GENERAL PROVISIONS**

- Sec.  
47.151. Definitions.  
47.152. Scope.  
47.153. Penalty.

**SPECIFICATIONS**

- 47.161. Entrances and windows.  
47.162. Gangways.  
47.163. Smoke, steam, gases, and dust.  
47.164. Lighting and heating.  
47.165. Sanitary conveniences.  
47.166. Lockers.  
47.167. Maintenance.

- 47.168. Employment of women.
- 47.169. Brass foundries.
- 47.170. Future cellar or basement foundries.
- 47.171. Existing cellar and basement foundries.

#### Authority

The provisions of this Subchapter E issued under the act of June 2, 1913 (P. L. 396, No. 267) (71 P. S. § 1442); and the act of May 18, 1937 (P. L. 654, No. 174) (43 P. S. §§ 25-1—25-15), unless otherwise noted.

#### Source

The provisions of this Subchapter E adopted August 16, 1929, amended through May 1, 1967, unless otherwise noted.

### GENERAL PROVISIONS

#### § 47.151. Definitions.

The following words and terms, when used in this subchapter, have the following meanings, unless the context clearly indicates otherwise:

*Basement*—A story partly, but not more than 1/2 below the level of the ground surrounding the building and shall be considered the first story of such building.

*Brass foundry*—A place where brass, aluminum, copper, tin, zinc, gold, silver, or composition metals containing any of the foregoing metals are melted or poured into molds in the making of castings, except that foundries where only aluminum is melted shall be covered by regulations governing iron and steel foundries.

*Cellar*—A story more than 1/2 below the level of the ground surrounding the building.

*Entrance*—A main doorway opening directly to the outer air.

*Gangway*—A well-defined passageway dividing the working floor of the foundry but not the spaces between molds. Spaces between molds shall be divided into three classes, which shall be known as bull-ladle aisles, hand-ladle aisles and buggy-ladle aisles.

*Iron or steel foundry*—A place where iron or steel or both metals are melted and poured into molds in the making of castings, together with cleaning, core making, drying, washrooms and toilet rooms, used in connection with the castings.

#### § 47.152. Scope.

This subchapter sets forth rules to safeguard the lives, limbs and health of workers in foundries, and places the responsibility of complying with these rules upon both employer and employe.

**§ 47.153. Penalty.**

Any person who violates this subchapter or any regulations of the Department or who interferes with the Department or its duly authorized representative in the enforcement of these provisions or regulations shall be penalized under the provisions of section 15 of act of May 18, 1937 (P. L. 654, No. 174) (43 P. S. § 25-15).

**SPECIFICATIONS****§ 47.161. Entrances and windows.**

Entrances to foundries shall be protected from November 1 to April 1 of each year by a covered vestibule, either stationary or movable, which shall be constructed so as to eliminate drafts and of such dimensions as to answer ordinary purposes, such as the passage of wheelbarrows, trucks and small industrial cars. This requirement does not apply to entrances used for railroad or industrial cars handled by locomotives or motors, or for traveling cranes, horse-drawn vehicles or automobiles. The entrances may remain open only for such time as is necessary for the ingress and egress of such cars, trucks, cranes, horse-drawn vehicles or automobiles. No locomotive shall remain inside the foundry during the loading or unloading of the cars.

**§ 47.162. Gangways.**

(a) Main gangways, where metal is carried by hand, bull or truck ladles, shall be not less than 5 feet wide. Truck-ladle gangways, which are not main gangways, shall be not less than 4 feet wide. Bull-ladle aisles between floors shall be not less than 3 feet wide. Single hand-ladle or buggy-ladle aisles between floors shall be not less than 18 inches wide. When trolleys are used over molding floors for pouring metal, the aisles shall be of sufficient width to permit the safe ingress and egress of employes and the safe use of the ladles. When it is necessary to occupy the central portion of the floor space in the production of castings, continuous gangway space shall be provided.

(b) During the progress of casting, each gangway or aisle shall be kept entirely free from undue dampness or obstruction of any kind. Each gangway shall be kept in good condition at all times. Each gangway used for industrial trucks shall be constructed of a hard material of substantial character, and the top of the rail shall be flush with the floor.

**§ 47.163. Smoke, steam, gases, and dust.**

(a) *Ventilation.* When smoke, steam, gases or dust, arising from any of the operations of the foundry, are dangerous to health or eyes, and when a natural circulation of air does not carry off such smoke, steam, gases or dust there shall be installed and operated hoods, ventilators, fans or other mechanical means of ventilation.

(b) *Castings.* The cleaning and chipping of castings shall be done in separate cleaning rooms, except that in existing installations where traveling cranes or cars are used for conveying castings into the rooms, a separating partition shall be erected not less than 12 feet in height. In existing installations, where the crane cage or crane girders do not permit the erection of a 12 foot partition, the height of the partition may be reduced sufficiently to permit the clearance of cranes and cars. Large castings may be chipped or cleaned by hand in the molding and casting room, if sufficient protection is furnished by the use of a curtain, screen, or some other means equally good to protect employes who are otherwise employed in the cleaning rooms. This requirement does not apply if mechanical contrivances are used for cleaning castings, and the dust and particles arising from it are effectively removed at the point of origin by an exhaust system.

(c) *Exhaust systems.* When tumbler mills are used, exhaust systems shall be installed to carry off effectively the dust arising from the cleaning of castings, except when the mill is operated outside the foundry. This requirement shall not prohibit the use of a water barrel to clean castings. Sand blast operations shall be carried on in the open air or in a separate room solely for such purposes. The milling of cupola cinders, when done inside the foundry, shall be carried on by an exhaust or water mill.

(d) *Floor slope.* The floor beneath and immediately surrounding the cupola shall slope and drain away from the base of it.

(e) *Compressed air.* Cores shall not be blown out of castings by compressed air, unless such work is done outside the foundry or in a special room or dust-proof enclosure. Men employed in cleaning castings by compressed air or sand blast shall be provided and wear approved head and eye protectors.

#### § 47.164. Lighting and heating.

(a) *Lighting.* The lighting of foundries shall conform to the requirements of Chapter 27 (relating to lighting).

(b) *Heating.* Proper and sufficient heat shall be provided and maintained in each foundry. Open fires may be used for the drying of molds or cores if coke containing less than 1% of sulphur is used. Also charcoal, gas or oils may be so used. If practicable, such drying of molds or cores shall be done at night.

(c) *Drying of ladles.* All hand and bull ladles shall be dried in ovens or outside of the foundry. A sufficient number of sheet-iron shields shall be available in iron foundries for use in covering hand and bull ladles.

(d) *Clothes of employes.* Suitable facilities shall be provided for the thorough drying of the clothing of employes. The facilities may be located in the wash-room, the locker room or in a room used exclusively for this purpose.

#### § 47.165. Sanitary conveniences.

(a) *Toilet rooms.* Each foundry employing ten or more persons shall provide and maintain for the use of the employes, in a place conveniently accessible and

connected with the foundry making it accessible without exposure to the open air, a toilet room of suitable size in which the employes may change their clothes. The toilet rooms shall have washbowls or washtroughs so arranged that water does not stand in them, of sufficient capacity adequately equipped with hot and cold water service. The washrooms shall be kept clean and sanitary and properly heated during cold weather. Each foundry shall establish and maintain separate from such toilet rooms, a suitable water closet. The toilet room and the water closet shall be connected with the foundry building making them accessible to it without exposure to the open air. They shall be properly heated, ventilated, cleaned and protected from the dust of the foundry. The requirement of the covered passageway between the foundry and the toilet rooms shall not apply to employes who as an ordinary part of their occupation work out of doors at all seasons of the year.

(b) *Toilet facilities.* Each foundry shall provide water closets or chemicals closets of an approved type, separate for each sex, in accordance with the following table:

<i>Number of Persons</i>	<i>Number of Closets</i>	<i>Ratio</i>
1—10	1	1:10
11—25	2	1:12 1/2
26—50	3	1:16 2/3
51—80	4	1:20
81—125	5	1:25

(c) *Additional employes.* For each additional 45 employes, or part of that number, the foundry shall provide one additional water closet.

(d) *Number of employes.* If less than 30 males are employed at one time, there shall be provided one individual urinal. If more than 30 and less than 80 males are employed, two urinals shall be provided, and thereafter one individual urinal shall be provided for every 80 men, or part of that number, employed. At least two linear feet of trough or slab urinal shall be considered the equivalent of one individual urinal.

(e) *Washbasins.* Washbasins with faucets for hot and cold water shall be supplied in accordance with the following table:

<i>Number of Persons</i>	<i>Number of Wash Basins</i>	<i>Ratio</i>
1—8	1	1:8
9—16	2	1:8
17—30	3	1:10
31—45	4	1:11 1/4
46—65	5	1:13

(f) *Additional employes.* For each additional 25 employes, or part of that number, at least one additional washbasin shall be supplied. Two feet of trough

and two faucets supplying hot and cold water, so arranged that the water supply may be mixed to the desired temperature, shall be considered the equivalent of a washbasin as set out in subsection (e). If it is desirable to mix the water supply at some location remote from the trough, an outlet for the mixed supply shall be provided for at least every 2 feet of trough.

(g) *Shower baths.* Washrooms installed after 1927, where 20 to 50 men are employed, shall be provided with at least one shower bath with an ample supply of hot and cold water. For each additional 50 men, or part of that number, at least one additional shower bath shall be provided.

(h) *Passageway.* If workmen are employed in heated rooms or buildings of foundries, and the required toilet facilities are provided in adjacent buildings or rooms, a covered passageway leading to such facilities shall be made to protect the workmen from a sudden change of temperature.

(i) *Calculation.* In using the tables of this section for calculating the number of facilities required, the maximum number of persons using the facilities at any time may be considered rather than the total number of persons employed.

#### § 47.166. Lockers.

Individual lockers, arranged for locking, shall be provided for employes and placed in a room used exclusively for such purpose, such as the washroom, the drying room, or at convenient places in the molding room. In cases of dispute, the necessity for, and the number of, such lockers shall be determined by the Board.

#### § 47.167. Maintenance.

(a) *Inspectors.* Ladles, shanks, tongs, slings, yokes, skimmers, and slag hoes used in the pouring of molten metal shall, prior to their use, be inspected daily as to their safety by the men preparing and using them. A regular inspection as to their safety shall be made once a month by a man designated for that purpose. A monthly inspection shall also be made of the chains and cables on counterweights used in connection with drying ovens, and a record kept of such inspections.

(b) *Fireways.* Fireways connected with drying ovens, when built in the floor, shall at all times be protected by either a substantial protecting cover or a standard railing as defined in Subchapter G (relating to railing, toeboards, open-sided floors, platforms and runways).

(c) *Trapdoors.* Trapdoors shall be guarded when open, either by standard railings as defined in Subchapter G or by watchman. All pits shall be covered or railed when not in use and sufficiently guarded at other times.

(d) *Passageways and stairs.* Passageways, stairways, inclines, runways, charging decks and platforms shall be properly lighted and have tread surfaces so constructed and maintained that persons walking on them do not slip or trip, and safeguarded with standard railings as defined in Subchapter G.



(e) *Worm gears.* All ladles pouring from the lip of 2,000 or more pounds capacity shall be equipped with a worm geared device for tilting the device. Ladles not so equipped shall be changed to conform with this requirement. All crane truck and trolley pouring ladles shall be so constructed that the center of gravity is below the bail, unless ladles are equipped with a geared device and a clip to prevent overturning.

(f) *Trunions.* Trunions on flasks shall sustain the loads they are required to handle. Trunions constructed after 1927 shall be carefully designed to carry the load they are to handle and constructed with a factor of safety of at least ten including bolts when they are used. The diameter of the button shall be equal to the diameter of the groove plus 1 1/2 times the diameter of the sling used to handle the flask. Inside corners shall be well filleted, and, in order to prevent the sling slipping off or riding the button, the radius of the corner between groove and button shall be approximately equal to the radius of the sling used with the remainder of the inside edge of the button straight. All trunions constructed after October 1, 1915, shall bear the date of their construction.

(g) *Explosives.* The use of high explosives on the foundry premises for the breaking of castings is prohibited unless effective protection is provided.

(h) *Drop.* The breaking of castings by the use of a drop inside the foundry during working hours is prohibited.

(i) *Drop outside the foundry.* When a drop is used for the breaking of castings or scrap outside of the foundry, a permanent shield of heavy planking or other effective protection shall be provided.

(j) *Safety devices.* Each employe shall use safety devices furnished for his protection by the employer, when there is a hazard connected with his employment.

(k) *Legs and feet.* Persons employed in iron or steel foundries who remove or handle pots or ladles containing molten metal from furnaces shall be provided with protection for the legs and feet and worn at all times while engaged in such work.

(l) *Head and eye.* Each employe whose head, eyes or neck is subject to injury from flying particles, heat or glare, or from the handling of molten metal shall be provided with and use protection as specified in Chapter 39, Subchapter C (relating to head and eye protection).

(m) *Tumbler barrels.* Tumbling barrels shall be guarded as follows:

(1) All drive belts, gears and shafting shall be guarded as required by Chapter 29 (relating to mechanical apparatus—miscellaneous) on all types of tumbling barrels.

(2) Horizontal revolving and reciprocating tumbling barrels operated singly or in a single line shall be guarded as follows:

(i) Loading and unloading sides shall be guarded either by a guard 6 feet high with not more than 1/2 inch mesh, such guard rising vertically or

inclined, or a hood over the barrel supported by counterweights. In either method it shall be interlocked with a belt shifter.

(ii) When a clearance of 15 inches on all sides of the barrel is obtained and the barrel revolved upwards from the loading and unloading sides with all projections pointed downward, no enclosure is required.

(3) When barrels operate back to back there shall be a platform over the shaft.

#### § 47.168. Employment of women.

(a) When rooms in which core ovens are located adjoin rooms where cores are made by females, and where the making of cores and the baking of cores are simultaneous operations, the partition between the rooms shall be constructed of concrete, hollow tile, brick, metal or other similar material, and there shall be in the partition only openings that are required by the nature of the business.

(b) Openings in partitions between the core oven room and the room in which females are employed shall be vestibuled with a revolving device, or double doors which shall be self-locking, or any other self-closing device equally effective. The device shall be kept in a condition that gases, fumes and smoke are effectively trapped.

(c) No female shall handle cores which have a temperature of more than 110°F.

#### § 47.169. Brass foundries.

(a) *Generally.* The regulations relating to dust, smoke, gases, fumes, ventilation, sanitation, heat, light, gangways, aisles, safety appliances, washrooms, cleaning rooms, drying and locker accommodations, as specified for iron and steel foundries, shall apply to brass foundries, except that main gangways shall be not less than 4 feet wide and gangways between molds on spill troughs not less than 3 feet wide.

(b) *Platform.* When the crown plate of an upright melting furnace is elevated above the surrounding floor in excess of 12 inches, the furnace shall be equipped with a platform guarded with a standard railing. The platform shall be constructed of metal or other fire-resistive material, extend along the front and sides of the furnace flush with the crown plate, be at least 4 feet in width, and be clear of all obstructions during pouring time. If the platform is elevated above the floor in excess of 12 inches, the lowering from the platform of crucibles containing molten metal shall be by mechanical means.

(c) *Crucibles.* When the combined weight of a crucible, tongs and molten metal exceeds 100 pounds, it shall be removed from the furnace and deposited on the floor by mechanical means.

(d) *Smoke boxes.* When smoke finish is desired on molds made on benches or tubs, smoke boxes which shall effectively trap the smoke shall be used and connected with flues to the outer air.

(e) *Molders.* When molders work side by side, at least 5 feet of space sideways shall be allowed for each employe, and a clear space of 3 feet shall be provided back of each employe.

(f) *Ventilators.* Hoods shall be provided directly above all brass melting furnaces using gas or oil as fuel, which effectively trap all gases and fumes generated in the melting of the metal. The hoods shall be provided with outlet pipes to lead the gases or fumes to the outer air. Ventilators shall be provided over all other furnaces used for melting brass or composition metal to effectively remove the gases above the furnaces.

(g) *Light.* Brass foundries shall be provided with natural light from at least two sides, or from at least one side with skylights in the roof.

(h) *Legs and feet.* Persons removing or handling pots containing molten metal from furnaces shall be provided with protection for the legs and feet.

(i) *Dirt riddling.* Gangway dirt and floor scrapings shall not be riddled in the room where workmen are employed, unless it is dampened so as to prevent the rising of dust.

(j) *Stoves.* When stoves for drying molds are located in the rooms used by workmen they shall be surrounded by a casing of fire-resistive material to the full height of the stove.

(k) *Ceiling.* No brass foundry shall be constructed after November 1, 1915, with a clearance less than 14 feet between the lowest point of the ceiling and the floor, except that where a peak, saw-tooth, monitor or arch roof is constructed, the side walls may be of a minimum height of 12 feet.

#### § 47.170. Future cellar or basement foundries.

No foundry shall be located after November 1, 1915, in a cellar or basement unless both the ceiling is at least 14 feet in height, measured from the finished floor to the under side of the ceiling, and proper and adequate provisions are made for lighting and ventilation. In addition to these two requirements if the foundry is, or is intended to be, located entirely in the front part of the building, the ceiling shall be in every part at least 6 1/2 feet above the curb level of the street in front of the building; or, if the foundry is or is intended to be located entirely in the rear part of the building or to extend from the front to the rear the ceiling shall be not less than 3 feet above the curb level of the street in front of the building and the foundry shall open upon a yard or court which shall extend 6 inches below its floor level.

#### Cross References

This section cited in 34 Pa. Code § 47.171 (relating to existing cellar and basement foundries).

#### § 47.171. Existing cellar and basement foundries.

If any foundry that was operated in a cellar or basement on October 1, 1915, is or was discontinued or closed by the Department, it may not be reopened as a

foundry unless there is strict compliance with § 47.170 (relating to future cellar or basement foundries). The occasional use of a foundry for the purpose of evading this requirement shall not be deemed a continuance of use of the foundry.

## Subchapter F. PRINTING AND RELATED INDUSTRIES

### GENERAL PROVISIONS

Sec.	
47.191.	Definitions.
47.192.	Scope.
47.193.	Workrooms.
47.194.	Exhaust systems.
47.195.	Safety.
47.196.	Dressing rooms.
47.197.	Sanitation.
47.198.	Water.
47.199.	Eating room.
47.200.	Photoengraving.
47.201.	Suggested safe practices.
47.202.	Penalty.

#### Authority

The provisions of this Subchapter F issued under act of June 2, 1913 (P. L. 396, No. 267) (71 P. S. § 1442); and act of May 18, 1937 (P. L. 654, No. 174) (43 P. S. §§ 25-1—25-15), unless otherwise noted.

#### Source

The provisions of this Subchapter F adopted October 9, 1918; amended through August 1, 1968, unless otherwise noted.

#### Cross References

This Subchapter cited in 34 Pa. Code § 11.85 (relating to applicable provisions of other regulations).

### GENERAL PROVISIONS

#### § 47.191. Definitions.

The following words and terms, when used in this subchapter, have the following meanings, unless the context clearly indicates otherwise:

*Bookbinding*—Any processes and operations connected with finishing of work, including cutting, ruling, folding, sewing, wire-stitching, bronzing, gluing and binding of pamphlets and books.

*Composition*—Processes and operations connected with casting or setting of type by hand or machine, and preparation of printing forms.

*Electrotyping*—Processes and operations connected with reproduction of printing surface by electrotyping.

*Lithographing*—Processes and operations connected with the production of lithograph stones and lithograph printing.

*Photoengraving*—Process and operations connected with the production of zinc, copper, or other metal printing plates by photoengraving.

*Presswork*—Operations and processes of printing machinery.

*Printing and allied industries*—Each individual, firm or corporation engaged in bookbinding, composition, electrotyping, lithographing, photoengraving, presswork, stereotyping and steel or copper plate printing.

*Stereotyping*—Processes and operations connected with the reproduction of printing surfaces by stereotyping.

*Steel or copper plate printing*—Processes and operations connected with the production of steel, copper, or other metal printing plates and dies, and steel plate printing and die stamping.

#### § 47.192. Scope.

This subchapter sets forth rules to safeguard the lives, limbs and health of workers employed in printing and related industries, and places the responsibility of complying with these rules upon both employer and employe.

#### § 47.193. Workrooms.

(a) *Heat.* Workrooms shall be adequately heated and ventilated by natural or mechanical means, and maintained at all times in a clean and sanitary condition.

(b) *Windows.* Workrooms shall have adequate light in all places where work is carried on, and windows shall be constructed to open for ventilation.

(c) *Ventilation.* Ventilation shall be secured through openings to the outer air so as to prevent drafts endangering the health or comfort of employes.

(d) *Lighting.* Artificial lighting shall have adequate intensity for each operation carried on, and lighting fixtures shall be fitted to minimize glare. Artificial lighting shall conform to the requirements of Chapter 27 (relating to lighting). When employes go off duty during the dark hours, lights shall be kept burning until they are safely out of the building.

(e) *Floors.* Floors of all rooms, where lead is used or handled, shall have smooth, even surfaces, permitting an easy removal of dust by vacuum cleaning, by flushing the floor with water or by sweeping after the floor has been sprinkled with a sufficient quantity of water, wet sawdust or other wet nonpoisonous material to lay all dust. Dry sweeping of the floors is prohibited.

(f) *Furniture.* Stands, racks or other articles of furniture shall be placed to avoid spaces between them which cannot be reached for cleaning and shall be so fixed to the floor that no dust may accumulate below them; or, installed with feet of sufficient height permitting the floor beneath them to be easily cleaned.

(g) *Type cases.* Type cases shall be cleaned under an exhaust hood, by vacuum cleaner, or outside the workroom in the open air. The use of bellows for blowing out dust in the room is prohibited.

(h) *Expectorating.* No person shall expectorate or spit upon the walls, floors or stairs of any building.

(i) *Cuspidors.* Cuspidors shall be provided without expense to the employes and shall be thoroughly cleaned each day or more often if necessary to maintain them in a sanitary condition.

(j) *Flushed with air.* Workrooms in which lead, chemicals or other poisonous substances are used or in which injurious fumes, dust, or gases are present, shall be thoroughly flushed with air each working day.

(k) *Wiping rags.* Wiping rags shall be of unstained, clean-washed and sterilized materials, free from buttons, pins or other obstructions.

(l) *Waste cans.* A nonleak receptacle of waterproof material equipped with a tight fitting cover, shall be provided in each workroom. All waste, liquid refuse and all other material which may either decay or have an offensive odor shall be deposited within this receptacle. This receptacle shall be kept covered except when material is being either deposited in it or removed from it; it shall be emptied and cleaned daily or more often if necessary to maintain it in a sanitary condition.

(m) *First aid kit.* Each establishment shall have available at all times and without expense to employes an approved first aid kit.

(n) *Containers.* Dross skimming from molten lead pots shall be poured as soon as practical into a container provided for this purpose. The container shall have a lid, and shall be kept closed except when it is either filled or emptied.

(o) *Gas pipe joints.* Gas pipe joints connected with gas heated machines shall be examined at least once each day to prevent air pollution from leaking gas.

(p) *Lead.* Employes shall be instructed to drop lead carefully into metal pots and to exercise care in avoiding the making of lead dust.

#### § 47.194. Exhaust systems.

(a) *Pipes.* All gas heated lead melting pots shall be equipped with exhaust hoods and exhaust pipes sufficient to remove all gas fumes.

(b) *Cleaning.* Plungers shall be cleaned under an exhaust hood or in a cleaning box. Type metal shall be cleaned either under an exhaust hood or by a vacuum system.

(c) *Discharge pipes.* The fumes from all exhaust pipes shall be discharged outside the workroom at a point where they cannot return to the building nor create a nuisance.

(d) *Approval.* Before construction work on exhaust systems is started, plans for these systems shall be submitted in duplicate to the Department for approval.

**§ 47.195. Safety.**

(a) *Additional requirements.* All power transmission machinery, machines, railings, toeboards, stationary steam engines, boilers, ladders, fire prevention and elevators, shall conform to the requirements of this part.

(b) *Signal system.* When more than one person is employed on a machine, an effective system of signal starting shall be adhered to rigidly.

(c) *Feeder guards.* Hand-fed machinery shall be guarded to protect persons employed as feeders. All power-driven guillotine paper cutters installed after July 1, 1933, shall be equipped with a two-handed tripping device and a nonrepeat device.

(d) *Platen guards.* Platen printing presses shall be installed with an approved type of feed guard.

(e) *Minors.* No persons under 18 years of age shall operate power-driven paper cutters or circular saws except qualified journeymen or apprentices and student learners as defined in § 11.21 (relating to definitions), and graduates of an approved vocational, technical or industrial education curriculum which prepared them for employment in the specific occupation.

**Source**

The provisions of this § 47.195 amended June 10, 1977, 7 Pa.B. 1592. Immediately preceding text appears at serial page (9227).

**§ 47.196. Dressing rooms.**

(a) *Lockers.* The employer shall provide each employe with a sanitary locker. For employes who make changes of clothing and whose working clothes may contaminate their street clothes with lead or other poisonous compounds or materials, the employer shall provide either an additional locker, a double locker, or such change-house facilities as are approved by the Department. All facilities shall be maintained in a clean and sanitary condition. Dressing rooms shall be provided for all female employes and shall be of solid construction and entirely separate from any workroom. In the dressing room, clothes hooks may be provided in lieu of lockers for the use of the female employes.

(b) *Couches.* Unless a hospital or emergency room, exclusively used for that purpose, is provided and maintained, there shall be provided in every dressing room for the use of females at least one couch or bed.

**§ 47.197. Sanitation.**

Sanitary facilities shall be provided in accordance with the requirements of Chapter 41 (relating to sanitation).

**§ 47.198. Water.**

(a) *Drinking.* The employer shall provide at all times, without expense to the employe, a sufficient supply of pure, cool drinking water.

- (b) *Cups.* A common drinking cup is prohibited.
- (c) *Ice.* Ice used for cooling purposes shall be applied in such a manner that the ice itself does not come in contact with the drinking water. The water from the melting ice shall not be mixed with the drinking water.
- (d) *Drinking fountains.* The drinking fountains or faucets shall be of such design and construction as to obviate the direct application of the lips to the water outlet.
- (e) *Cleaning.* Water receptacles shall be thoroughly cleansed weekly and then sterilized with steam or with boiling water.
- (f) *Physical examination.* Employees engaged in the care and maintenance of drinking facilities shall be determined, by physical examination, to be free of communicable diseases.

**§ 47.199. Eating room.**

No employe or other person shall take or be permitted to take any food or drink of any kind into any workroom where lead or other poisonous compounds or materials are handled.

**§ 47.200. Photoengraving.**

- (a) *Ventilation.* All rooms in which the processes of plate developing, zinc etching, line etching and plate printing are carried on shall be adequately ventilated by natural or mechanical means. If mechanical means are necessary, plans for installation shall be approved by the Department.
- (b) *Rubber gloves.* The employer shall provide without expense to the employe rubber gloves for the use of glass washers, and when required, to zinc and copper-etchers and re-etchers.

**§ 47.201. Suggested safe practices.**

It is recommended that the following safe practices be adhered to and a notice of them be posted by the employer in a conspicuous place of each establishment:

**POISONS IN PRINTING**

Lead, the main constituent of type metal is absorbed into the system chiefly from the stomach and in small part from the lungs and possibly from the skin. The dust of the workrooms always contains lead in very finely divided form. Unless very great precautions are taken this settles on the floor, the hands, or the lips, and is in this way carried to the stomach. Taken into the body, it produces:

- Colic;
- Constipation;
- Paralysis;
- Disease of the heart, blood vessels, and kidneys;



Insanity; and  
Death.

Protect yourself from it in every way.

Do not splash metal from your melting pots; it dries, becomes dust, and you inhale the lead.

Never hold type in your mouth.

Do not permit dry sweeping of your workroom or dusting of the fonts while you are present. The only safe way of cleaning during working hours is vacuum cleaning.

Do not keep your lunch exposed to the dust of the workroom.

Never touch food or place your fingers in your mouth without first washing your hands thoroughly. A nail file or other instrument for cleaning the nails, a brush, hot water and soap are necessary if the lead is to be removed thoroughly. Benzine is often used to clean the ink from the rolls of the printing presses.

Poisoning from this substance produces:

Faintness;  
Dizziness;  
Headache; and  
Vomiting.

This material should be used only in places that are well ventilated.

Anilin oil forms a part of some of the mixtures, used in cleaning rolls. It is more poisonous than benzine and, in addition to the symptoms given under benzine, may, in severe cases, cause:

Convulsions, or  
Death.

Find out whether or not the cleaning mixture contains anilin oil. If it does, use it only in well-ventilated rooms. Do not splash any of it on your body, your clothes, or the floor. You may be poisoned by absorbing it through the skin or by breathing the fumes as the liquid evaporates.

Poisonous gases are given off by all fires. In addition, most gas fires do not burn up all the gas but allow some of it to escape into the room. See that all fires have flues in good working order leading to the outside air in order to carry away any gases that might injure your health.

#### TUBERCULOSIS

Of every 1,000 deaths among printers, 292 are caused by tuberculosis. To have this disease you must take the germ into your body. You may get it from the common drinking cup, the common towel, or from your coughing neighbor who spits on the floor. If your employer does not provide individual cups and towels, provide your own. Your health is worth it. Plenty of cuspidors conveniently placed and in a clean shop ought to prevent everybody from spitting on the floor.

## INACTIVITY

Long sitting or standing in one position, especially in rooms without plenty of fresh air, cause poor circulation of the blood. Overcome this by plenty of exercise in the open air after working hours.

## LIGHT

If you cannot have daylight for your work, endeavor to have all artificial lights properly placed and shaded so as to keep the glare from your eyes. You need the best light possible to do your work quickly and well. A printer with eyesight ruined is a printer out of a job.

Death from tuberculosis or lead poisoning is absolutely unnecessary. If you contract either of these diseases, see your physician at once. Both are curable if treatment is begun early and carefully carried out.

## HOW TO PREVENT SICKNESS

1. Do not go to work on an empty stomach; this weakens the system.  
Do not put fingers in the mouth.  
Do not take food into the workrooms.  
Do not eat food in the workroom.

Before eating and before leaving work thoroughly wash your face, arms, and hands with soap and warm water; cleanse your nose and rinse your mouth with water.

2. Take a bath frequently, every day if possible. Cleanliness is one of the best preventives of sickness.

3. Do not chew tobacco while at work, for in handling tobacco with dirty hands the dust may be carried by your fingers into your mouth.

4. Alcoholic liquors weaken the system and make it more liable to disease. All employes are urged to abstain from the use of all alcoholic liquors.

5. Drink plenty of good milk.

6. Keep your finger nails clean and cut short so that dust can not collect under and around them.

7. It is better not to wear a mustache or beard as they collect dust. If worn it is better to keep them cut short and wash them thoroughly every day.

8. To have good health you must keep your bowels open. Whenever constipated, take a dose of Epsom or Glauber's salts or other laxative.

9. Dry sweeping is prohibited. The floors and walls should be cleaned either with a vacuum cleaner, or flushed with water, or swept only after being thoroughly sprinkled with a sufficient quantity of wet sawdust to lay all dust thoroughly.

10. If a workman finds that he is affected by lead, he should leave this trade.

11. If ill consult a physician at once. Do not endanger your health by taking home remedies or the advice of friends or drug clerks who are not licensed physicians.

**§ 47.202. Penalty.**

Any person who violates this subchapter or any regulations of the Department or who interferes with the Department or its duly authorized representative in the enforcement of these provisions or regulations shall be penalized under section 15 of act of May 18, 1937 (P. L. 654, No. 174) (43 P. S. § 25-15).

**Subchapter G. RAILINGS, TOEBOARDS, OPEN-SIDED FLOORS,  
PLATFORMS AND RUNWAYS**

**GENERAL PROVISIONS**

Sec.	
47.221.	Definitions.
47.222.	Scope.
47.223.	Penalty.

**RAILINGS FOR ALL INSTALLATIONS**

47.231.	Installation.
47.232.	Construction.
47.233.	Pipe railings.
47.234.	Metal railings other than pipe.
47.235.	Wood railings.
47.236.	Stairway railings and handrailings.
47.237.	Exceptions.

**TOEBOARDS FOR ALL INSTALLATIONS**

47.241.	Installation.
47.242.	Construction.
47.243.	Exceptions.

**RUNWAYS AND PLATFORMS FOR ALL INSTALLATIONS**

47.251.	General requirements.
47.252.	Chain railings.
47.253.	Access to platforms.
47.254.	Exceptions.

**RAILINGS FOR NEW INSTALLATIONS**

- 47.261. Post fastenings.
- 47.262. Angle.
- 47.263. Wood post fastenings.

**OILING PLATFORMS—NEW INSTALLATIONS**

- 47.271. New platforms.

**RAILINGS—EXISTING INSTALLATIONS**

- 47.281. Post fastenings.
- 47.282. Wood posts.

**TOEBOARDS—EXISTING INSTALLATIONS**

- 47.291. Exceptions.

**OILING PLATFORMS—EXISTING INSTALLATIONS**

- 47.301. Platforms.

**APPENDIX**

**Authority**

The provisions of this Subchapter G issued under act of May 18, 1937 (P. L. 654, No. 174) (43 P. S. §§ 25-1—25-15), unless otherwise noted.

**Source**

The provisions of this Subchapter G adopted February 10, 1926; amended through August 1, 1968, unless otherwise noted.

**Cross References**

This Subchapter cited in 34 Pa. Code § 5.118 (relating to transportation, machinery, and platforms); 34 Pa. Code § 5.165 (relating to repairs); 34 Pa. Code § 5.181 (relating to general); 34 Pa. Code § 11.52 (relating to heating and passing rivets); 34 Pa. Code § 13.172 (relating to platforms); 34 Pa. Code § 29.148 (relating to oiling and cleaning); 34 Pa. Code § 29.171 (relating to all installations); This Subchapter cited in 34 Pa. Code § 39.22 (relating to yard and internal housekeeping); 34 Pa. Code § 39.33 (relating to construction); 34 Pa. Code § 45.32 (relating to floor openings); 34 Pa. Code § 47.89 (relating to tank processes); and 34 Pa. Code § 47.167 (relating to maintenance).

**GENERAL PROVISIONS****§ 47.221. Definitions.**

The following words and terms, when used in this subchapter, have the following meanings, unless the context clearly indicates otherwise:

*Balcony*—A working platform projecting from a wall.

*Handrailing*—A single pole, bar or pipe supported on brackets from a wall or partition.

*Oiling platform*—A raised flooring constructed for the purpose of oiling machinery.

*Platform*—A raised working floor or stage.

*Railing*—A vertical barrier erected along the exposed edges of open-sided floors, working platforms, runways, balconies and openings in walls, floors and ground levels.

*Runway*—A stationary incline or ramp provided as a means of ascent and descent from one level to another.

*Toeboard*—A board or plank set on edge immediately under a railing at floor level.

**§ 47.222. Scope.**

This Subchapter sets forth rules to safeguard the lives, limbs and health of workers in industries in which railings, toeboards, open-sided floors, platforms and runways are used, and places the responsibility of complying with these rules upon both employer and employe.

**§ 47.223. Penalty.**

Any person who violates this subchapter or any regulations of the Department or who interferes with the Department or its duly authorized representative in the enforcement of these provisions or regulations shall be subject to summary proceedings before an alderman, magistrate, or district justice, and upon conviction shall be penalized under the provisions of section 15 of act of May 18, 1937 (P. L. 654, No. 174) (43 P. S. § 25-15).

**RAILINGS FOR ALL INSTALLATIONS****§ 47.231. Installation.**

Railing shall be installed along the edges of every open-sided floor, working platform, runway or balcony which is 6 feet or more above floor or ground level and along the edges of all other platforms or openings in walls, floors or ground levels where the safety of persons is involved. Railings or handrailings shall be installed on all stairways 3 feet or more in height.

**Cross References**

This section cited in 34 Pa. Code § 47.253 (relating to access to platforms).

**§ 47.232. Construction.**

(a) Railings shall be not less than 42 inches in height from floor or ground level to the top of the top railing and shall be provided with an intermediate railing the center of which shall be midway between the floor or ground level of the space guarded and the top of the top railing. Railings shall be constructed in a permanent and substantial manner of wood, pipe, metal shapes or metal bars. Reference should be made to Plates 1, 2 and 3 of the Appendix to this Subchapter. One or more sides may be hinged or supported in sockets if a rigidity equal to that of fixed installation is obtained. Railings shall be smooth and free from large or loose knots, protruding nails, bolts, splinters, fins, slivers and cracks. All sharp corners shall be rounded and smoothed. The ends of railings shall not overhang the terminal posts unless such overhang does not constitute a projection hazard.

(b) Posts or uprights shall be spaced not more than 8 feet center to center. Reference should be made to Plates 1, 2, 3 and 5 of the Appendix.

(c) Railings made of wood, metal shapes or metal bars shall be placed on that side of the posts or uprights which afford the greatest support and protection. Reference should be made to Plate 3-B,C of the Appendix.

**Cross References**

This section cited in 34 Pa. Code § 47.234 (relating to metal railings other than pipe); 34 Pa. Code § 47.235 (relating to wood railings); and 34 Pa. Code § 47.253 (relating to access to platforms).

**§ 47.233. Pipe railings.**

(a) *Top rails.* Pipe railings shall be not less than 1 1/4 inches inside diameter if of iron and not less than 1 1/2 inches outside diameter if of brass tubing. Reference should be made to Plate 1 of the Appendix.

(b) *Midrails.* The middle railing shall be of a diameter not less than the minimum requirement for the top railing.

(c) *Posts.* The posts or uprights for pipe railings shall be of a diameter not less than the minimum requirement for the top railing. Specially formed metal or cast posts other than pipe are acceptable if they are equal in strength to a pipe post of the above diameter. Reference should be made to Plate 5 of the Appendix. Posts which are an integral part of the under or over structure are acceptable if they meet the spacing and strength requirements specified in this section.

(d) *Sockets.* Removable pipe railings having the posts supported by sockets are acceptable if the sockets are of a depth not less than 1/3 of the height of the railing and if all sockets are lined with pipe of a diameter large enough to permit ease of insertion and withdrawal of the posts without permitting sidesway. Reference should be made to Plate 1-B of the Appendix. When pipe posts are sup-

ported by U-bolts fastened in the structural frame, the length of post so supported shall be equal to 1/3 of the height of the railing.

(e) *Special fastenings.* Metal posts or uprights of other types used in connection with pipe railings shall be secured to the floor or structural frame in such manner as to achieve a rigidity equal to the requirements of existing and new post fastenings. Reference should be made to Plate 5-B of the Appendix.

#### Cross References

This section cited in 34 Pa. Code § 47.235 (relating to wood railings); 34 Pa. Code § 47.234 (relating to metal railings other than pipe); and 34 Pa. Code § 47.235 (relating to wood railings).

### § 47.234. Metal railings other than pipe.

(a) *Angle.* Metal railings other than pipe shall be of a section at least equal in strength to that of 1 1/2 by 1 1/2 by 3/16 inch angles. Reference should be made to Plate 2 of the Appendix.

(b) *Midrails.* The middle railings shall be of a section at least equal in strength to the minimum requirement for top railings.

(c) *Posts.* The posts or uprights shall be of a section at least equal in strength to the minimum requirements for railings. Posts which are an integral part of the under or over structure are acceptable if they meet the spacing requirements of § 47.232 (relating to construction) and strength requirements of § 47.233 (relating to pipe railings).

#### Cross References

This section cited in 34 Pa. Code § 47.235 (relating to wood railings).

### § 47.235. Wood railings.

(a) *Top rails.* Wood railings shall be not less than 2 inches by 4 inches finished size. Reference should be made to Plate 3-B of the Appendix of this Subchapter.

(b) *Alternate type.* A top railing of 1 inch by 4 inches finished size is acceptable if another board of not less than 1 inch by 4 inches finished size is securely fastened to the sides of the posts and to the top railing at approximately right angles to the top railing. Reference should be made to Plate 3-C of the Appendix.

(c) *Midrails.* Middle railings shall be not less than 1 inch by 4 inches finished size.

(d) *Posts.* Wood posts or uprights shall be at least equal in section to 2 inches by 4 inches finished size. Specially formed metal or cast posts, used in connection with wood railings, are acceptable if they meet the rigidity and strength requirements specified for these posts in §§ 47.233—47.234 (relating to pipe railings; metal railings other than pipe). Wood posts which are an integral part of the under or over structure are acceptable if they meet the spacing and strength

requirements specified in §§ 47.232—47.233 (relating to construction; pipe railings.) Reference should be made to Plate 3 of the Appendix.

**§ 47.236. Stairway railings and handrailings.**

(a) Railings for stairways shall be not less than 36 inches in height from the middle of the tread to the top of the railing. The closed sides of stairways shall have only a handrailing. The open sides of stairways shall have a top and middle railing with toeboard. No toeboards shall be installed on stairways when there is no danger of objects falling on persons working below. Reference should be made to Plate 6-A,B of the Appendix.

(b) Railings for stairways shall conform in all other respects to the specifications for railings. On the closed sides of stairways, handrailings shall be supported by wall brackets which shall be spaced not more than four feet apart.

**§ 47.237. Exceptions.**

(a) *Opening covers.* If it is impractical to use railings, floor and ground level openings shall be guarded by covers. This exception applies only if, when the covers are removed, the openings are guarded with standard removable railings. The covers shall be of sufficient strength to withstand the heaviest load to which the surrounding area may be subjected to the usual course of operations.

(b) *Balustrades.* Balustrades may be installed in lieu of standard railings if the posts of the balustrades meet the height, spacing and fastening requirements specified for railings and if the space between the top railing and the floor is filled in so as to afford protection equal to that supplied by a middle rail and toeboard. Balustrades 36 inches in height from the middle of the tread may be installed on stairways.

(c) *Panels.* When the panels between posts and top rail and floor are fitted with substantial expanded metal, wire mesh or solid material, the middle railing may be omitted.

(d) *Omission.* The middle railing is not required on platforms used only for lumber storage.

(e) *Height.* In connection with festooners, drying rooms and other operations which require the operator to frequently reach across the railings provided, the Department may accept railings not less than 36 inches high if they conform to all other requirements.

(f) *Chains.* In the case of pits and other floor or ground level openings, such as pouring pits in foundries, and runways and platforms where the nature of the operations requires that railings be frequently removed, chains of equal strength may be used in place of standard railings. Such chains shall be taut when in place. When chains are used, the spacing, strength and fastening specifications for posts shall be the same as for standard rails. The use of rope or wire cable in place of chains is prohibited.



(g) *Omission.* Railings are not required around pits and other openings when they are so constructed that the top of the pit or opening is 42 or more inches above floor or ground level.

### TOEBOARDS FOR ALL INSTALLATIONS

#### § 47.241. Installation.

A toeboard shall be installed under the railing along the edges of each working platform, runway or balcony which is 6 or more feet above floor level and along the edges of all other platforms and openings in walls floors and ground levels when the safety of persons is involved.

#### Cross References

This section cited in 34 Pa. Code § 47.291 (relating to exceptions).

#### § 47.242. Construction.

(a) Toeboards shall be constructed in a permanent and substantial manner of metal, wood or other material that is equivalent in strength. Perforations up to 1/2 inch is permitted. Toeboards shall be smooth and free from protruding nails, bolts, splinters, fins and slivers.

(b) Wood toeboards shall be at least equal in cross section to 1 inch by 6 inches finished size. Sheet metal toeboards shall be at least 1/8 inch by 6 inches. When other material is used, the strength shall be equal to the requirement for sheet metal. Reference should be made to Plates 1,2,3, and 5 of the Appendix.

(c) Toeboards shall fit tightly to the floor and fastened by straps or angles secured by bolts or rivets. If possible the toeboard shall be fastened to the post or upright of the railing. Reference should be made to Plates 1-A,C; 2-A,B,C; 3-A,C; 5-A of the Appendix.

#### Cross References

This section cited in 34 Pa. Code § 47.291 (relating to exceptions).

#### § 47.243. Exceptions.

Toeboards are not required on the following:

- (1) On platforms used only for lumber storage.
- (2) In connection with chain railings.
- (3) On oiling platforms.
- (4) On stairways where there is no danger of objects falling on persons working below.

**RUNWAYS AND PLATFORMS FOR ALL INSTALLATIONS****§ 47.251. General requirements.**

Runways and platforms, except those erected for a specific temporary purpose, shall be constructed in a permanent and substantial manner. Runways or platforms 6 or more feet above floor or ground level shall have all open sides guarded with standard railings and toeboards. Runways or platforms constructed over conveyors used for the movement of materials, regardless of height, shall have all sides guarded with standard railings and toeboards.

**§ 47.252. Chain railings.**

On runways and platforms where frequent removal of railings is necessary in the course of usual operations, chains of equal strength may be used in place of standard railings. The chains shall be taut when in place. Toeboards are not required in spaces guarded by chains.

**§ 47.253. Access to platforms.**

Safe means shall be provided for reaching all elevated platforms. Platforms of permanent construction which are in general use shall have a permanent runway or stairway equipped with either a stationary ladder or handrailings in §§ 47.231—47.232 (relating to installation; construction).

**§ 47.254. Exceptions.**

(a) The requirements for elevated runways and platforms shall not apply to the following:

- (1) Small platforms for motors or other similar equipment unless there is standing room of at least 18 inches in width on the platform beside the equipment.
- (2) Shelves used for the storage of material on which persons have no occasion to stand.
- (3) Platforms used for loading and unloading freight.
- (4) Runways used in filling tank cars when equipped with standard railing on one side.
- (5) Platforms used for pouring molten metal.

(b) Toeboards and intermediate rails are not required on platforms used only for storing lumber.

**RAILINGS FOR NEW INSTALLATIONS****§ 47.261. Post fastenings.**

Pipe posts shall be fastened to the floor or structural frame by pipe flanges secured by rivets, tap bolts, or through-bolts with plates or washers in the case of steel construction or through-bolts with plates or washers in the case of wood

construction. When fastened to wood, the bolts shall be so arranged that no two bolt holes are in line with the grain of the wood. Each flange shall be secured by not less than four rivets or bolts of sufficient diameter to insure a permanent rigid anchorage. Other approved methods of securing pipe flanges to concrete floors may be used. Reference should be made to Plate 1-C, D, E and Plate 4 of the Appendix.

**Cross References**

This section cited in 34 Pa. Code § 47.281 (relating to post fastenings).

**§ 47.262. Angle.**

The posts or uprights shall be fastened to the floor or structural frame by rivets, tap bolts or through-bolts with plates or washers in the case of steel construction or by through-bolts with plates or washers in the case of wood construction or by angle post sockets. When fastened to wood, the bolts shall be so arranged that no two bolt holes are in line with the grain of the wood. If angle post sockets are used, the throat of the socket shall have a depth of not less than four inches, the post shall be fastened to the socket by at least two bolts, and the socket shall be riveted to the floor or structural frame in the case of steel construction or through-bolted to the floor with plates or washers in the case of wood construction. The socket shall be secured to the floor or structural frame by at least four bolts or rivets. Reference should be made to Plate 2-B, C, D of the Appendix.

**§ 47.263. Wood post fastenings.**

Wood posts shall be fastened to the floor or structural frame by straps, angles or brackets. Straps, angles and brackets shall be secured to the posts and to the floor by through-bolts with plates or washers. If wood posts are fastened directly to the structural frame, they shall be secured by through-bolts with plates or washers. No two bolt holes shall be in line with the grain of the wood.

**Cross References**

This section cited in 34 Pa. Code § 47.282 (relating to wood posts).

**OILING PLATFORMS—NEW INSTALLATIONS**

**§ 47.271. New platforms.**

Oiling platforms shall be constructed in a permanent and substantial manner at least 18 inches in width with a standard railing along one side. Toeboards are not required on oiling platforms.

**RAILINGS—EXISTING INSTALLATIONS****§ 47.281. Post fastenings.**

(a) Existing installations having the flanges secured by lag or ordinary wood screws or other means are acceptable if safety is assured and if major repairs or replacements are made the specifications for new installations are followed.

(b) Existing installations having the posts secured by means other than those specified in § 47.261 (relating to post fastenings) are acceptable if safety is assured, and if repairs or replacements are made the specifications for new installations shall be followed.

**§ 47.282. Wood posts.**

(a) Existing installations having the posts secured by means other than those specified in § 47.263 (relating to wood post fastenings) are acceptable if safety is assured and if repairs or replacements are made to meet the specifications for new installations.

(b) All types of existing installations having posts which are not secured in accordance with the requirements of this subchapter may be required by the Department to have such posts substantially stay braced.

**TOEBOARDS—EXISTING INSTALLATIONS****§ 47.291. Exceptions.**

(a) Toeboards of not less than three inches in height may be accepted by the Department if they conform to the requirements of §§ 47.241—47.242 (relating to installation; construction).

(b) Toeboards of not less than 7/8 inch in thickness may be accepted by the Department if they conform to the requirements of §§ 47.241—47.242.

**OILING PLATFORMS—EXISTING INSTALLATIONS****§ 47.301. Platforms.**

Oiling platforms not less than 12 inches in width may be accepted by the Department if they are of permanent and substantial construction with a standard railing along one side.

APPENDIX

PLATE I

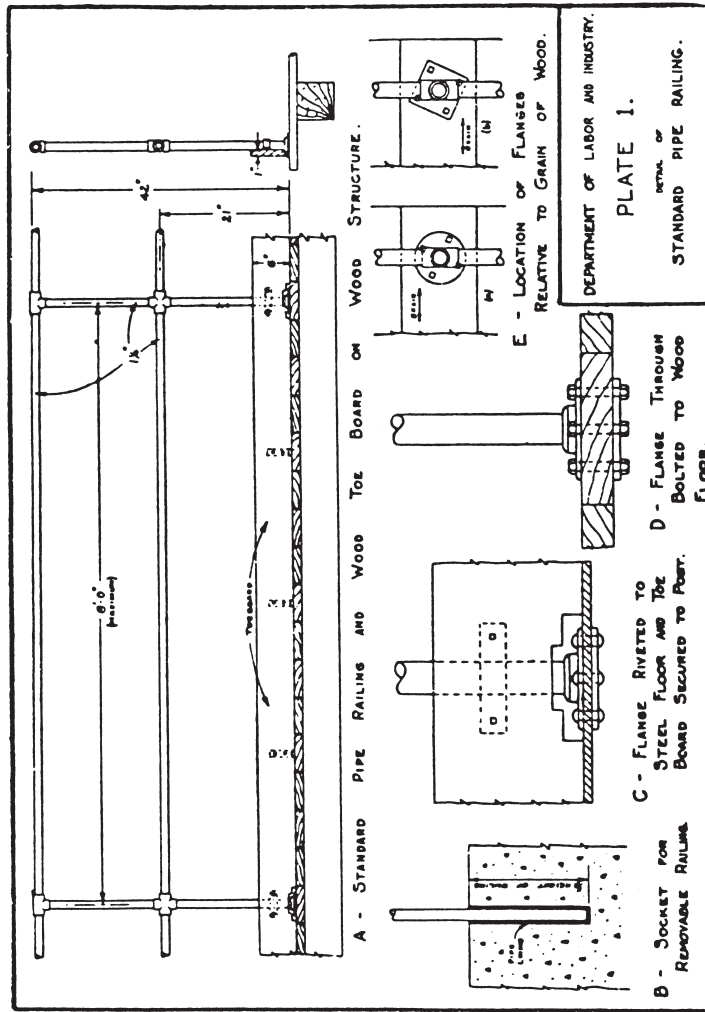

PLATE 2

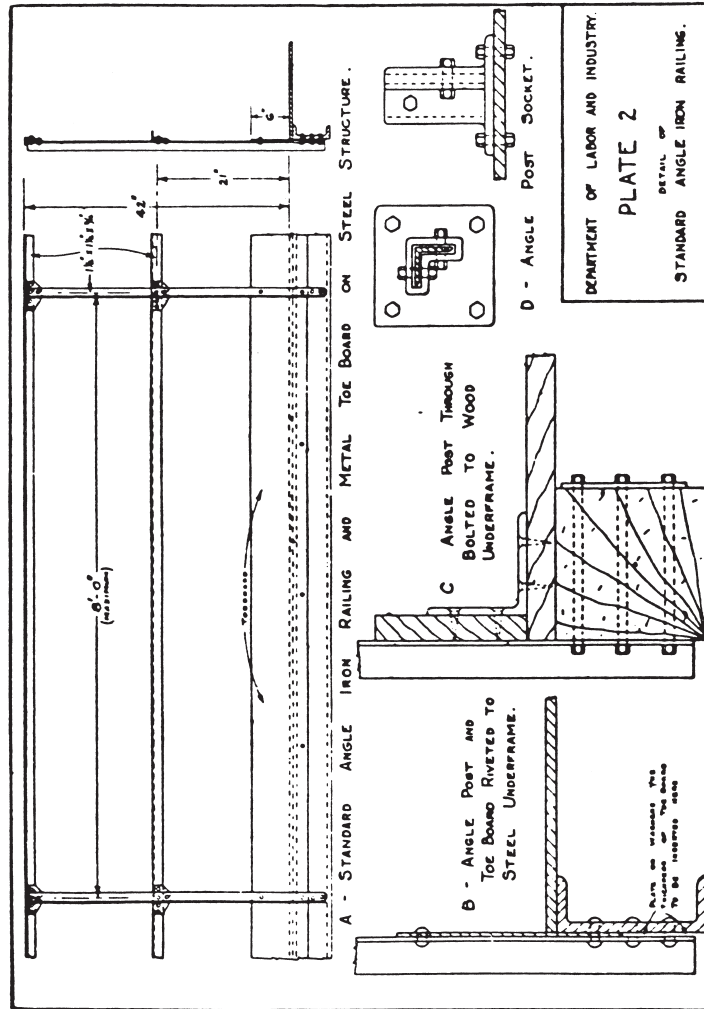
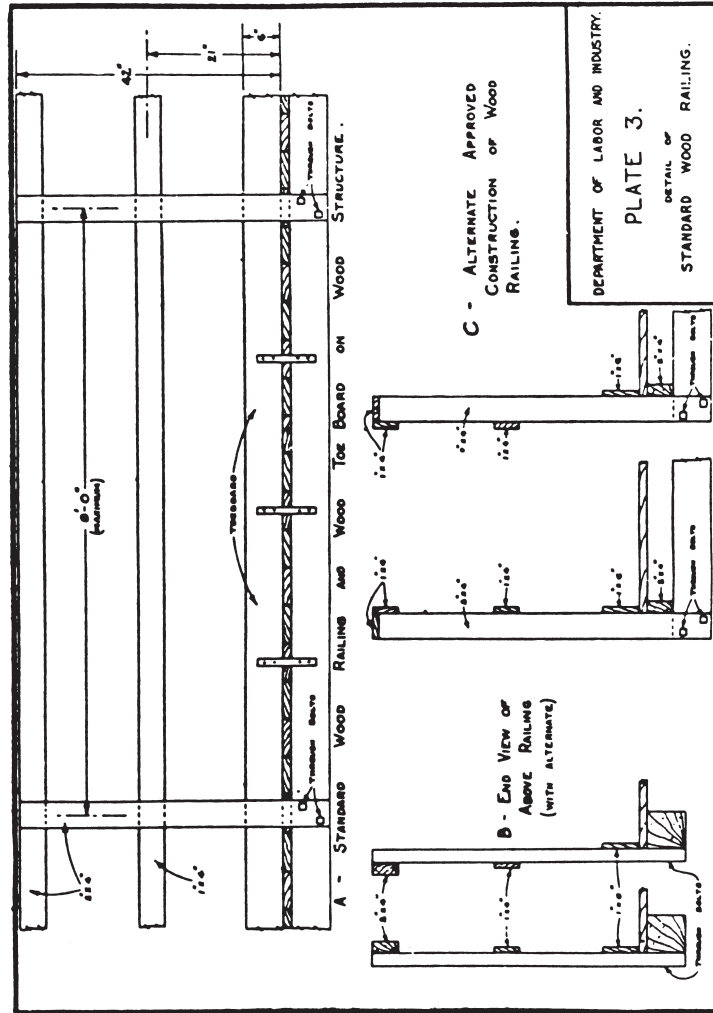

PLATE 3



DEPARTMENT OF LABOR AND INDUSTRY.  
PLATE 3.  
DETAIL OF  
STANDARD WOOD RAILING.

PLATE 4

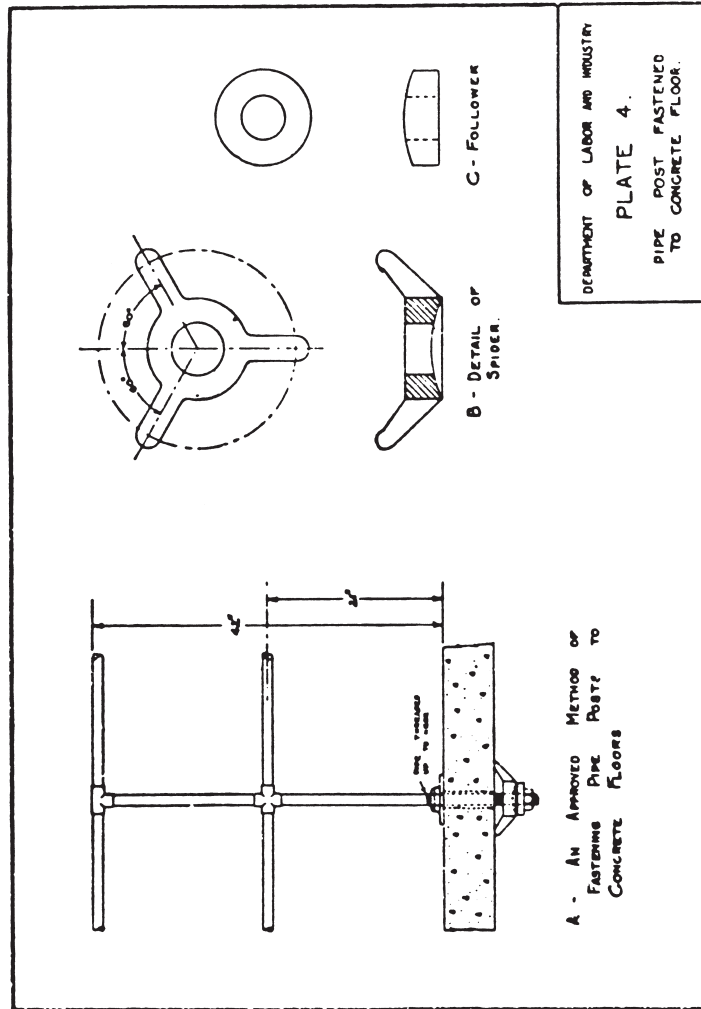



PLATE 5

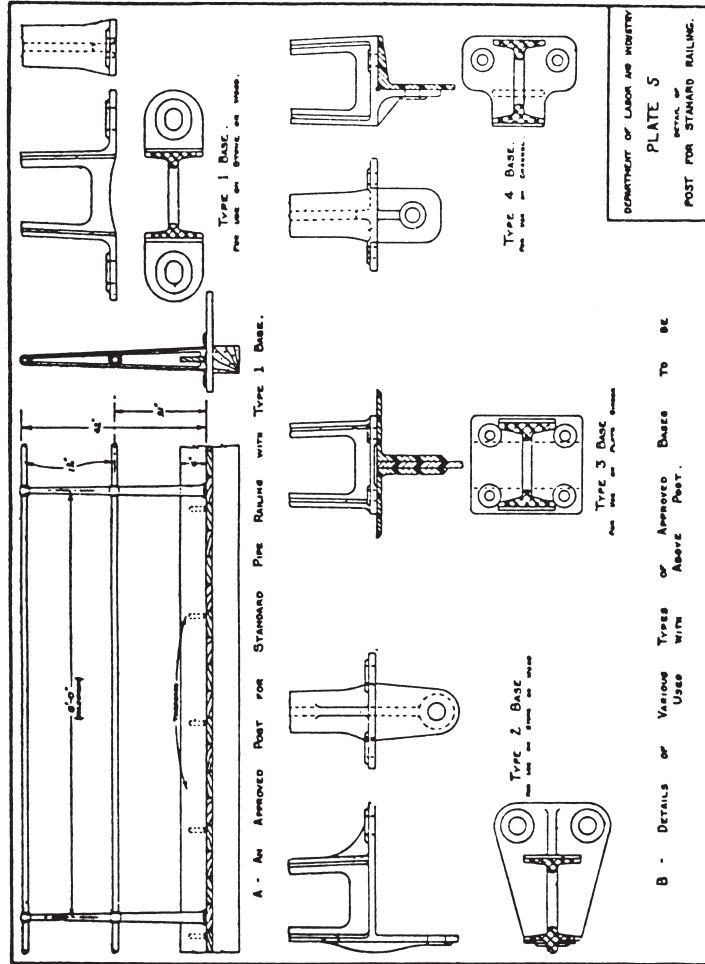
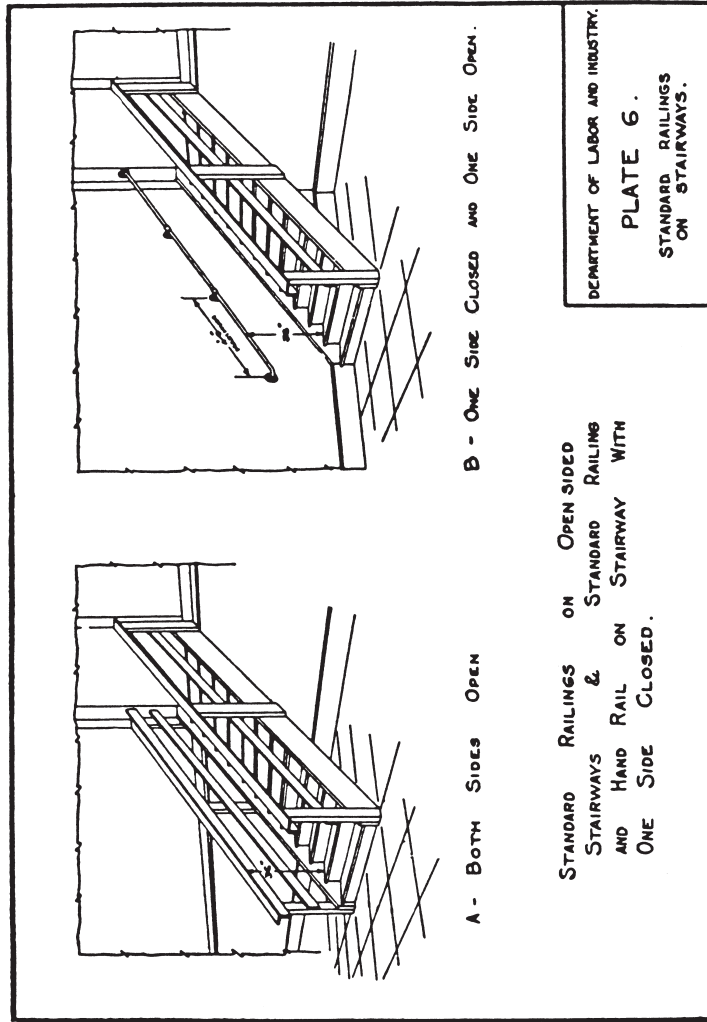

PLATE 6



**Subchapter H. STUFFED TOYS****GENERAL PROVISIONS**

- Sec.  
 47.311. Definitions.  
 47.312. Scope.  
 47.313. Penalty.  
 47.314. Registration.  
 47.315. Seal of approval.  
 47.316. Filling material.  
 47.317. Tolerances.  
 47.318. Sterilization.

**CLASSIFICATION OF FLAMMABILITY**

- 47.321. Fabrics.  
 47.322. Nonfabric.

**Authority**

The provisions of this Subchapter H issued under act of July 25, 1961 (P. L. 855, No. 372) (35 P. S. §§ 5201—5209), unless otherwise noted.

**Source**

The provisions of this Subchapter H adopted November 24, 1961; amended through September 25, 1969, unless otherwise noted.

**GENERAL PROVISIONS****§ 47.311. Definitions.**

The following words and terms, when used in this subchapter, have the following meanings, unless the context clearly indicates otherwise:

*Acetate*—A manufactured fiber in which the fiber-forming substances consist of cellulose acetate. When not less than 92% of the hydroxyl groups are acetylated, the term triacetate may be used as a generic description of the fiber.

*Acrylic*—A manufactured fiber in which the fiber-forming substance is any long chain synthetic polymer composed of at least 85% by weight of acrylonitrile units.

*Azlon*—A manufactured fiber in which the fiber-forming substance is composed of any regenerated naturally occurring proteins.

*Cellulose fiber*—The fibers obtained from wood pulp and compressed into pads. The label designation shall be “cellulose fiber pad.”

*Cotton*—This term shall not be used by itself.

*Excelsior*—The fine shredded, thread or ribbon-like fiber of wood, but does not include waste products such as sawdust, shavings or similar materials. The term wood wool is prohibited. The label designation shall be

*Feathers*—The feathers of the designated fowl which are whole in physical structure with the natural form and curvature originally found in the feathers. The origin of the feathers shall be stated on the label.

*Garnetted clippings*—New material which has been made into fabric and subsequently cut up, torn up, broken up or ground up and run through a garnetting machine and thoroughly processed.

*Glass*—A manufactured fiber in which the fiber-forming substances is glass.

*Hair*—The coarse, filamentous epidermal outgrowth of such animals as horses, cattle, hogs, and goats. This term shall not be used by itself, but shall be used as follows:

- (i) *Horse hair*—The hair of the manes or tails of horses.
- (ii) *Cattle hair*—The hair from the tails of cattle.
- (iii) *Hog hair*—The bristles and body hair of swine.
- (iv) *Body hair*—The short soft hair removed from the bodies of animals.
- (v) *Goat hair*—The hair from any species of goats.

*Importer*—Any person as defined in the act of July 25, 1961 (P.L. 855, No. 372) (35 P. S. §§ 5201—5209) who imports from foreign countries or states materials that are within the scope of the act, and sold, distributed or given away in this Commonwealth.

*Kapok*—The fibrous growth contained in the pod of the kapok tree.

*Latex foam rubber*—Natural or synthetic rubber latex which has been converted from a liquid state to a stable foamy mass and molded or otherwise assembled into suitable shapes for commercial use.

*Metallic*—A manufactured fiber composed of metal, plastic coated metal, metal coated plastic or a core completely covered by metal.

*Modacrylic*—A manufactured fiber in which the fiber-forming substance is any long chain synthetic polymer composed of less than 85% but at least 35% by weight of acrylonitrile units.

*New*—Any article or material which has not been used prior to being utilized as part of a stuffed toy.

*Nylon*—A manufactured fiber in which the fiber-forming substance is any long chain synthetic polyamide having recurring amide groups as an integral part of the polymer chain.

*Nytril*—A manufactured fiber containing at least 85% of a long chain polymer of vinylidene dinitrile and the vinylidene dinitrils content is no less than every other unit in the polymer chain.

*Olefin*—A manufactured fiber in which the fiber-forming substance is any long chain synthetic polymer composed of at least 85% by weight of ethylene, propylene or other olefin units.

*Polyester*—A manufactured fiber in which the fiber-forming substance is any long chain synthetic polymer composed of at least 85% by weight of an ester of a dihydric alcohol and terephthalic acid.

*Polystyrene foam beads*—A filling material which has been processed into small round droplets usually from 0—1/2 inch in diameter.

*Rayon*—A manufactured fiber composed of regenerated cellulose, as well as manufactured fibers composed of regenerated cellulose in which substituents have replaced not more than 15% of the hydrogens of the hydroxyl groups.

*Rubber*—A manufactured fiber in which the fiber-forming substance is comprised of natural or synthetic rubber.

*Saran*—A manufactured fiber in which the fiber-forming substance is any long chain synthetic polymer composed of at least 80% by weight of vinylidene chloride units.

*Sawdust*—Small particles of wood produced by sawing.

*Shredded clippings*—New material which has been made into fabric and subsequently cut up, torn up, broken up or ground up, but which has not been run through a garnetting machine nor thoroughly processed.

*Shredded latex foam rubber*—Latex foam rubber which has been subjected to a shredding process.

*Shredded synthetic foam*—Synthetic foams which have been subjected to a shredding process.

*Shredded paper byproduct*—Paper removed from various machine operations in the preparation of manufacturing other products and subsequently cut up, torn up, broken up, or ground up.

*Sisal*—The fiber obtained from the agave plant. This term shall be used when the material is new and does not consist of waste, or reclaimed fibers. If made of waste or reclaimed fibers, the term reprocessed sisal fiber shall be used.

*Spandex*—A manufactured fiber in which the fiber-forming substance is a long chain synthetic polymer comprised of at least 85% of a segmented polyurethane.

*Synthetic foam*—Material made of synthetic products other than synthetic rubber and produced in a resilient foam-like state. The label designation shall include terms describing the recurring units or groups of the polymerized or copolymerized product. For example, the foam derived from polyesters and diisocyanate shall be termed polyurethane.

*Textile clippings*—Material which has been made into thread, yarn or fabric but not reduced into a fibrous state.

*Textile fiber waste*—Combination of fiber of undetermined generic kind.

*Thermoplastic beads*—Synthetic resins formed into small beads or pellets.

*Vinal*—A manufactured fiber in which the fiber-forming substance is any long chain synthetic polymer composed of at least 50% by weight of vinyl alcohol units and in which the total of the vinyl alcohol units and any one or more of the various acetal units is at least 85% by weight of the fiber.

*Vinyon*—A manufactured fiber in which the fiber-forming substance is any long chain synthetic polymer composed of at least 85% by weight of vinyl chloride units.

*Wool*—Fibers from the fleece of the sheep which have not been reclaimed from any woven or felted product or from any byproduct of manufacturing. The label designation shall be wool.

#### Source

The provisions of this § 47.311 amended September 15, 1978, 8 Pa.B. 2596. Immediately preceding text appears at serial pages (9252) to (9253).

#### Cross References

This section cited in 34 Pa. Code § 47.316 (relating to filling material).

### § 47.312. Scope.

(a) This subchapter sets forth rules relating to stuffed toys, and places the responsibility of complying with these rules upon the manufacturers, retailers, distributors or other persons having the article or material in their possession.

(b) This subchapter applies to manufacturers or importers of all stuffed toys sold, distributed or given away in this Commonwealth.

### § 47.313. Penalty.

Any person who violates this subchapter or any regulations of the Department or who interferes with the Department or its duly authorized representative in the enforcement of these provisions or regulations shall upon conviction be penalized in accordance with section 9 of act of July 25, 1961 (P. L. 857, No. 372) (35 P. S. § 5209).

### § 47.314. Registration.

(a) Applications for registration shall be accompanied by a sample of all products within the scope of this subchapter, manufactured by the applicant for sale, distribution or gift in this Commonwealth. The application shall be accompanied by a notarized statement of the manufacturer or of an authorized officer of the manufacturer, that the submitted samples have been selected at random from the products offered for sale by the manufacturer.

(b) No importer shall import articles within the scope of this subchapter unless they have been approved by the Department. However, the importer may consider himself as the manufacturer for purposes of this subchapter and apply for registration as such manufacturer might do.

(c) Within 15 days after any change in or concerning a toy which makes the information previously submitted with respect to it erroneous or inaccurate in any respect, or within 15 days of commencement of a new toy as to which information has not been previously submitted the manufacturer or importer shall submit

to the Department the information required by subsection (a) of this section concerning such new or changed toys.

**§ 47.315. Seal of approval.**

(a) Each stuffed toy manufactured for sale, delivered, consigned or possessed for sale, sold or offered for sale, gift or use in this Commonwealth shall have securely affixed to it a tag or label. The form, design, color or size of the label is left to the discretion of the manufacturer or importer, but the information required on the label shall be clearly legible and in sufficient size type so that it may be readily discerned.

(b) The label of a stuffed toy shall bear the following information:

(1) A statement that all new material or all new (type) material was used in the manufacture of the stuffed toy.

(2) The registration number of the manufacturer or importer assigned by the Commonwealth preceded by the abbreviations "REG. NO. PA."

(c) No person other than the one granted a given registration or his designated agent shall use the registration number.

**Source**

The provisions of this § 47.315 amended through September 15, 1978, 8 Pa.B. 2596. Immediately preceding text appears at serial pages (19123) to (19124).

**§ 47.316. Filling material.**

When filling material is designated on the article or package in which the article is contained, the filling material shall be designated by its accepted generic term as set forth in § 47.311 (relating to definitions).

**§ 47.317. Tolerances.**

Toys shall be declared unfit for sale, gift or use in this Commonwealth if they contain any of the following:

(1) Material of sufficient size to visibly reveal a pattern, weave, or other mechanical unification of threads to indicate prior use or a previous manufacturing process.

(2) Dirt or any other foreign matter in excess of 1% by weight.

(3) More than 1% oil or grease.

(4) More than .002% lead (as Pb)—20 parts per million.

(5) More than .0002% arsonic (as As<sub>2</sub>O<sub>3</sub> —two parts per million.

(6) More than 5% ammonia.

(7) More than 1% urea.

(8) Plastic or metal ornaments such as eyes and nose not of a safety design or not attached to the stuffed toy so as to prevent removal.

(9) Stones or other hard materials having jagged or sharp edges.

(10) Material bearing electrostatic charge with adherence characteristics which when exposed could lodge in the windpipe, ears or nostrils.

(11) Filling material which surface burns at a rate of less than three seconds for 12 square inches.

**Source**

The provisions of this § 47.317 amended August 3, 1973, 3 Pa.B. 1471. Immediately preceding text appears at serial page (9255).

**§ 47.318. Sterilization.**

(a) Any process used for the disinfecting of new material of animal origin shall not be deemed to afford proper and thorough disinfecting unless the process effectually removes disease producing spores, germs and bacilli, insects and insect nites, animal matter subject to decay, and dirt and filth to a degree which is not harmful or dangerous to the user.

(b) Each applicant for a certificate of disinfection shall give a detailed description of the process to be employed, accompanied with a random sample of such product of animal origin.

**CLASSIFICATION OF FLAMMABILITY**

**§ 47.321. Fabrics.**

Classes I, II and III include stuffed toy coverings accepted as having no unusual burning characteristics; class IV includes all coverings which are considered dangerously flammable and recognized as being unsuitable for stuffed toys because of their rapid and intense burning. The classification for fabrics shall be as follows:

<i>No nap, pile, tufting, flock, or other type raised fiber surface</i>	<i>Napped, pile, tufted, flocked, or other type raised fiber surface</i>
---	--

*Class I (Relatively slow burning)*

When time of flame spread is 20 seconds or more for 12 square inches.	When time of flame spread is over seven seconds for 12 square inches.
---	---

*Class II (Moderately flammable)*

When time of flame spread is eight to 19 seconds for 12 square inches.	Burns with a rapid surface flash in less than seven seconds for 12 square inches, with no fusing or ignition of base fabric.
--	--



*No nap, pile, tufting, flock, or other type raised fiber surface*

*Napped, pile, tufted, flocked, or other type raised fiber surface*

*Class III (Relatively flammable)*

When time of flame spread is three to seven seconds for 12 square inches.

When time of flame spread is from four to seven seconds, both inclusive, for 12 square inches with fusing or ignition of base fabric.

*Class IV (Rapid and intense burning)*

When time of flame spread is less than three seconds for 12 square inches.

When time of flame spread is less than four seconds for 12 square inches with fusing or ignition of base fabric.

**§ 47.322. Nonfabric.**

Nonfabric materials include plastics, paints, and nonfabric portions of a stuffed toy. These materials which meet the requirements in class V are accepted as having no unusual burning characteristics. Materials which have burning characteristics as set forth in class VI are considered dangerously flammable and recognized as unsuitable for stuffed toys because of their rapid burning and intense burning. The classification shall be as follows:

*Class V*

Such materials shall be classified as normal flammability when a nine square inch sample does not burn or flash the full area during a four second flame exposure.

*Class VI*

Such materials shall be classified as rapid burning when a nine square inch sample burns or flashes the full area during a four second flame exposure.

**Subchapter I. TEXTILE INDUSTRIES**

**GENERAL PROVISIONS**

- Sec.  
47.341. Scope.  
47.342. Apparatus.  
47.343. Machines.  
47.344. Exhaust systems.

**DYEING AND FINISHING**

- 47.351. Heating and ventilating.
- 47.352. Special hazards.
- 47.353. Penalty.

**Authority**

The provisions of this Subchapter I issued under act of May 18, 1937 (P. L. 654, No. 174) (43 P. S. §§ 25-1—25-15), unless otherwise noted.

**Source**

The provisions of this Subchapter I adopted January 1, 1925; amended through August 1, 1968, unless otherwise noted.

**GENERAL PROVISIONS****§ 47.341. Scope.**

This subchapter sets forth rules to safeguard the lives, limbs and health of workers in textile industries, and places the responsibility of complying with such rules upon both employer and employe.

**§ 47.342. Apparatus.**

Mechanical power transmission apparatus shall be guarded according to the requirements of Chapter 29, Subchapter C (relating to mechanical power transmission apparatus).

**Cross References**

This section cited in 34 Pa. Code § 47.351 (relating to heating and ventilating).

**§ 47.343. Machines.**

(a) The machines listed in this section are those of known danger for which efficient guards are in common use. Other machines may be added from time to time as practical methods of guarding are devised.

(b) Machines shall be guarded as follows:

(1) *Picker, opener, willow*. Picker, opener, willow and similar equipment hopper feed shall be provided or the feed rolls shall be provided with a cover or guard arranged to protect the fingers of the operator while feeding material. The cylinder shall have a cover and be so interlocked that the cover does not open while the machine is in motion.

(2) *Cangill boxes*. A slotted cast iron guard through which the material passes shall be provided for the horizontal calendar roll at the delivery end of the machine.

(3) *Shear-revolving knife*. Shear shall have a cover or barrier bar arranged to protect the fingers of the operator from contact with the knife.

(4) *Washer (laundry type), dry tumbler drum.* A device shall be provided which acts to prevent the inside barrel from moving when the revolving drum door is open. If the revolving barrel is not enclosed by the machine itself no interlock is required but the barrel shall be smooth or so guarded as to prevent accidental contact with employes.

(5) *Centrifugal extractor (whizzer).* Each centrifugal extractor or whizzer shall be equipped with a metal cover provided with an interlocking device that prevents the cover from opening while the basket is in motion and the power operation of the basket while the cover is open. The device shall not prevent the movement of the basket by hand to insure an even loading. Each machine shall have an effective brake mechanically operated.

(6) *Hussong machines.* The superintendent shall cause all chains used in connection with Hussong machines to be inspected at least once a month and a report of such inspections shall be kept on file, accessible to inspectors of the Department at all times. The superintendent shall also be responsible for the constant supervision of the machines to insure that work is done under the safest possible conditions.

(7) *Flat work ironer.* Feed rolls shall be provided with a bar across the front so arranged that the striking of the bar by the hand of the operator stops the machine. Pressure rolls shall be covered or guarded to prevent a person from reaching into the rolls without removing the guard. This may be either a vertical guard on the sides or a complete cover depending upon which type of machine is used.

(8) *Power guillotine cutter.* A device shall be provided which, in order to operate the machine, requires the use of both hands in a position sufficiently distant from the point of operation of the machine so that the hands of an operator are not caught under the descending cutter.

(9) *Slitter.* A guard which completely encloses the cutting discs shall be provided to protect the fingers of the operator from accidental contact with the cutting edges when the machine is in operation.

(10) *Sewing machines.* Power-driven single needle sewing machines used for straight sewing without folders shall be provided with an approved needle guard so that the fingers of the operator are protected from accidentally slipping under the needle. The guard shall be of such form that the needle may be threaded conveniently without removing the guard.

(11) *Looms.* Pins or studs in eccentric motion of looms in or along passageways shall be guarded. An approved shuttle guard shall be provided.

#### Cross References

This section cited in 34 Pa. Code § 47.351 (relating to heating and ventilating).

**§ 47.344. Exhaust systems.**

The following machines shall be covered and exhaust systems shall be installed for the removal of dust or fly:

- (1) Dusting and opening machines in the manufacture of woolen and worsted yarns such as willows, burr pickers, and mixing pickers.
- (2) Machines used in the preparation of cotton for carding of cotton yarns such as openers and pickers.
- (3) Machines used in the manufacture of cotton yarns on cotton waste cards such as willows, pickers, and openers.
- (4) Machines used in the spinning of asbestos yarn such as willows, pickers, and cards.
- (5) The cylinders, workers, strippers, and doffers of cards for carding cotton waste shall be enclosed. Exhaust systems are not required.

**DYEING AND FINISHING****§ 47.351. Heating and ventilating.**

(a) The requirements of this section in addition to the requirements of §§ 47.342—47.343 (relating to apparatus; machines) shall be complied with in dyeing and finishing establishments.

(b) Dye houses shall be equipped with ventilating systems which will produce the following conditions:

(1) During the months of November, December, January, February, March, April and May, the temperature of the dye house shall be maintained between 40°F and 95°F. During this period when the weather is clear and the outside temperature is 40°F or more, the dye house shall be kept free from steam to a height of 6 feet from the floor. The ventilating system employed to produce this freedom from steam shall be maintained in operation during less favorable weather conditions.

(2) During the months of June, July, August, September and October, the dye house shall be kept free from steam at all times to a height of 6 feet from floor.

(c) The systems which are used to produce the conditions set forth in subsection (b) may consist of ventilating fans, heating coils, hoods with flues attached over kettles or introduction of hot air on other natural ventilating devices.

**§ 47.352. Special hazards.**

(a) *Caustic soda or potash.* When caustic soda or caustic potash is used, means shall be provided for emptying containers in which the material is received without employees coming in contact with the caustic. Steam solution towers or specially arranged hoists and vats with provisions to prevent splashing may be used for this purpose.

(b) *Carboys.* Carboys shall be provided with inclinators or the acid dispensed from them by pumps or hand operated siphons. The carboys shall not be stored close to steam pipes.

(c) *Clear water, oils, soda.* If corrosive materials such as concentrated acid or caustic soda are used, clean water shall be piped so as to be within easy reach of employes. A solution of bicarbonate of soda shall be available for use in cases of acid burns, and a supply of mineral or vegetable oil shall be kept on hand at all times for the relief of victims of caustic soda burns. Care shall be exercised to prevent the deterioration of these preparations.

(d) *Pipes and drains.* Dye kettles and vats which may at any time contain hot or corrosive liquids shall not empty on the floor but shall be provided with pipes or drains of sufficient capacity to carry off the contents of the vat without backing up on the floor.

(e) *Tanks and vats.* Tanks and vats containing hot or corrosive liquids shall be so protected that employes do not accidentally fall into them. This may be done either by railings or other means or by elevating the tank or vat to a height of 3 or more feet above the floor or working platform.

#### § 47.353. Penalty.

Any person who violates this subchapter or any regulations of the Department or who interferes with the Department or its duly authorized representative in the enforcement of these provisions or regulations shall be subject to summary proceedings before an alderman, magistrate, or district justice, and upon conviction shall be penalized under the provisions of section 15 of act of May 18, 1937 (P. L. 654, No. 174) (43 P. S. § 25-15).

### Subchapter J. WINDOW CLEANING

#### GENERAL PROVISIONS

Sec.	
47.371.	Definitions.
47.372.	Scope.
47.373.	Application.
47.374.	Specification of materials.
47.375.	Belts and ropes.
47.376.	Terminals.
47.377.	Anchors.
47.378.	Test reports.
47.379.	Methods of fastening anchors.
47.380.	General requirements.
47.381.	Inspection.
47.382.	Penalty.

**Authority**

The provisions of this Subchapter J issued under act of May 18, 1937 (P. L. 654, No. 174) (43 P. S. §§ 25-1—25-15), unless otherwise noted.

**Source**

The provisions of this Subchapter J adopted November 15, 1932; amended through August 1, 1967, unless otherwise noted.

**GENERAL PROVISIONS****§ 47.371. Definitions.**

The following words and terms, when used in this subchapter, have the following meanings, unless the context clearly indicates otherwise:

*Double-head anchor (four bolt system)*—Two anchor heads in the window frame on each side of the window made and installed according to this subchapter. Each pair of anchor heads shall be used simultaneously and not singly.

*Window cleaning*—The operation of washing, wiping or other methods of cleaning windows.

**§ 47.372. Scope.**

This subchapter applies to all window cleaning operations over which the Department has supervision, sets forth rules to safeguard the lives, limbs and health of workers who engage in window cleaning, and places the responsibility of complying with these rules upon both employer and employe.

**§ 47.373. Application.**

(a) *Safety devices.* In buildings having windows with sills 12 or more feet above the grade or adjoining flat roof, and so constructed that it is necessary to clean the windows from the outside, approved safety devices for the protection of the window cleaner shall be provided. When windows are cleaned on the inside from sills located more than 12 feet above the floor or working platform, or when windows are of such size that they cannot be cleaned from the sills, approved devices such as ladders or scaffolds built or erected in accordance with this subchapter shall be used.

(b) *Sills.* In buildings, where the window sill extends less than 6 inches out from the window frame, an approved portable auxiliary sill or other approved device shall be provided. Portable sills shall not be less than 10 inches wide nor less than 30 inches long. Portable sills or other devices shall be so designed and constructed that are safely held in place and readily put into position and removed.

(c) *Alterations.* When windows are so constructed and it is usual or practicable to clean them from the inside, alterations, changes and obstructions which

make it necessary to clean such windows from the outside, shall not be made unless provision is also made for safety devices.

(d) *Windows at balconies.* This subchapter shall not apply to a window opening to fire escape balcony or other balcony more than 2 feet wide and not more than 12 inches below the window sill.

(e) *New construction.* In buildings erected after November 15, 1932, approved anchors for window cleaners shall be installed at the time of erection and shall be indicated on the plans of the buildings except for the following:

(1) When casement windows are provided which may be cleaned from inside the building.

(2) When windows are so designed as to necessitate cleaning from the outside of the building by scaffolds.

(f) *Existing construction.* In all existing buildings which lack anchors for window cleaners, approved anchors shall be installed, or the windows shall be cleaned from scaffolds or ladders which are in accordance with the regulations of the Department.

(g) *Anchors.* Anchors for window cleaners installed before November 15, 1932, may remain if acceptable to the Department.

(h) *Belts.* Belts for window cleaners in use before November 15, 1932, may continue to be used if the Department determines them to be in a safe condition. Belts procured after such date shall be in accordance with this subchapter.

#### § 47.374. Specification of materials.

(a) *Brass.* Brass or other approved durable corrosive-resistive material of equal strength or toughness shall have an ultimate tensile strength of not less than 50,000 pounds per square inch and elongation not less than 15% in two inches. When the material is annealed, the tensile test shall be made after annealing.

(b) *Leather.* Leather shall be oak tanned, free of glucose, salts, adulterants and acid.

(c) *Canvas.* Canvas shall be of double web and stitched.

(d) *Rope.* Rope shall be not less than 1/2 inch diameter Yacht Manila. It shall be from fiber of fine texture and flexible, yet hard enough to wear well.

#### § 47.375. Belts and ropes.

(a) Approved safety belts shall be of oak-tanned leather, canvas or other approved equally strong durable material. The belt shall be so designed and constructed that safety terminals do not pass through their fastenings on the body belt of the window cleaner in case one terminal becomes loosened from its window anchor.

(b) Rope, if used, shall be of Yacht Manila, or its equivalent. It shall not be less than 1/2 inch in diameter and shall be doubled in such a manner that the tearing of one section of the rope does not affect the safety of the window cleaner. Larger sizes of rope shall be of corresponding higher minimum tensile strength.

(c) Ropes or straps secured to eyes or rings shall be provided with metal thimbles to prevent wear.

**§ 47.376. Terminals.**

(a) The ends of the belt shall be fitted with approved heavy forged or cast metal safety terminals of brass, or other approved durable corrosive-resistive materials. If cast they shall be properly annealed.

(b) Safety belt terminals shall have slots not less than 4 inches long. The slots shall be 1/2 inch wide and that portion of the slot which passes over the anchor head shall be 7/16 inch deep by 1 inch wide and shall have an approved catch to prevent the automatic or accidental release of the terminal.

(c) Right angle sections of terminals shall have 1/8 inch radius fillets in all inside corners.

(d) All other metal parts, fittings, rivets and thimbles shall be of the same strength and specifications as the safety terminals.

**§ 47.377. Anchors.**

(a) When the anchor head comes in contact with the belt terminal while in use, the terminal shall be not less than 1/4 inch thick.

(b) Anchors shall be forged and of the same material as the terminals. Anchors shall be of the twin or double headed type designed for attachment to window frames, mullions or masonry.

(c) The anchor heads shall be not less than 5/8 inch across the flat and 9/32 inch thick nor more than 3/4 inch across and 21/64 inch thick. The area of the neck of each anchor head shall be not less than the area of a 3/8 inch round.

(d) Anchors shall have 1/8 inch radius fillets at all places where diameters or other dimensions change. Wail flanges shall be not less than 1-1/4 inches in diameter.

(e) The space between the underside of the anchor head and the upperside of the flange or window frame shall be not less than 1/2 inch or more than 7/8 inch.

(f) Double anchor heads shall be spaced not less than two or more than three inch centers.

(g) The back face of anchors for installation in wood window frames or mullions shall be provided with at least two sharp lugs to prevent turning of the anchor after installation; other equally effective and approved methods may be used.

(h) The anchors on the building to which safety belts are fastened shall be installed at a point not less than 42 inches or more than 51 inches above the window sill.

**§ 47.378. Test reports.**

When application is made for approval of anchors, belts or ropes the information presented to the Department shall include the following:



(1) Test report or other documentary evidence showing that the materials from which the metal parts and the nonmetallic parts are made conform to the specifications of this subchapter, or test reports of individual metal parts showing a minimum ultimate tensile strength of 1,500 pounds.

(2) Test report showing that waist band, ropes or terminal straps, and all interconnecting parts have been subjected to test separately, and as an assembled unit, and have shown sufficient strength to hold a suspended load of 1,000 pounds.

**§ 47.379. Methods of fastening anchors.**

Anchors shall be attached to the building in the following manner:

(1) *Brick masonry and concrete construction.* Bolts or shanks shall be not less than eight inches in length and shall be imbedded their full length or shall extend through the wall. They shall be not less than 3/8 inch in diameter if round and shall be forged or rolled. If rectangular, they shall be not less than 1/4 inch in thickness and having a minimum sectional area of at least as great as a 3/8 inch diameter round. These bolts or shanks shall have either a right angle bend of at least 2 inches at the end or a metal washer riveted, or otherwise securely fastened to the end of the bolt or shank. The washer shall be at least four square inches in area and shall be imbedded in the masonry. Bolts or shanks shall be made of the same material as the anchor.

(2) *Wood construction.* Bolts or shanks shall be not less than 3/8 inch in diameter made of the same material as the anchor, shall pass through the entire window frame or mullion, and shall be securely fastened by a nut and washer. The ends of the bolts or shanks shall be upset to prevent loosening or removal of the nuts.

(3) *Hollow metal frame construction.* The anchor fittings shall be attached by three bolts 5/16 inch in diameter, of the same material as the anchor and shall pass through a steel plate not less than 5/16 inch thick, 3/4 inch wide by 6 inches long. This steel plate shall be bolted or riveted by at least two 1/4 inch bolts, screws or rivets of the same material as the anchor to a part of the frame protected by masonry or concrete. The ends of all bolts shall be upset to prevent loosening or removal of the nuts. As an alternate, each anchor fitting may be attached to the frame and reinforcing plate by means of at least three 5/16 inch screws of the same material and strength as the anchor, threaded and screwed into the plate to a depth of at least 5/16 inch. All screws used in the installation of anchors to metal frame construction shall have the threads terminate far enough from the screw head to prevent weakening due to undercutting.

(4) *Solid metal construction.* Anchor fittings shall be attached by three 5/16 inch bolts of the same material as the anchor. The bolts shall pass through the frame and shall be securely held in place by nuts and washers on the inside. The ends of the bolts shall be upset to prevent loosening or removal of the nuts.

Where the nature of the solid metal frame construction is such that this method cannot be followed, it is permissible to drill and tap the metal frame and install the anchor with at least three 5/16 inch diameter screws made of the same material as the anchor and screwed into the frame to a depth of at least 3/8 inch. All screws used in the installation of anchors to metal frame construction shall have the threads terminate far enough from the screw head to prevent weakening due to undercutting.

(5) *Other approved method.* Any other method of attaching anchors shall be approved by the Department.

#### § 47.380. General requirements.

(a) *Scaffolds.* When windows are cleaned from a scaffold, the scaffold shall be built in accordance with the regulations of the Department pertaining to scaffolds.

(b) *Ladders.* When ladders are used they shall be fitted with safety feet or other suitable means to prevent slipping and shall comply in all respects with Chapter 21 (relating to ladders). When ladders of over 18 feet in length are used, a man shall be stationed at the foot of the ladder to hold it in place while the window cleaner is on the ladder.

(c) *Safety devices.* Window cleaners shall use safety devices provided for their protection. Window cleaners shall not pass from window to window on the outside unless a supported railing is installed. Existing safety devices and methods of window cleaning other than those specified in this section shall be approved by the Department.

(d) *Anchors.* In buildings with windows where the distance between anchors is greater than 6 feet, there shall be installed special approved anchors at each side of the window frame. The anchors shall be set 42 inches above the window sills.

(e) *Back support.* The owner shall provide for each window when it is being cleaned a brass cable or chain to be attached to the anchors as a back support for the window cleaner. In addition there shall be installed above these anchors, standard belt anchors to which the window cleaner shall attach his belt.

(f) *Mullion windows.* If masonry openings for mullion windows are more than 5 feet 6 inches wide at least one anchor fitting shall be installed in each mullion.

(g) *Casement windows.* Casement windows which cannot be wholly cleaned while standing at the inside shall have anchor fittings installed in the same manner as specified for other windows.

#### § 47.381. Inspection.

(a) *Anchors.* Anchors shall be regularly inspected by the owner of the equipment at least once every 6 months. Anchors that have become loose or worn shall be immediately replaced.

(b) *Belts.* Belts and ropes of window cleaners shall be inspected by the owner of the equipment at least once each week, and a record kept as to the condition and age of the equipment. Belts, ropes or terminals that show signs of wear or weakness shall be removed from service. The record of the inspections shall be kept in the office of the owners of the equipment and shall be opened to representatives of the Department on demand.

(c) *Ladders and scaffolds.* Ladders and scaffolding equipment shall be inspected by the owner of the equipment at least once each month and a record kept of the condition of the equipment. Broken or badly worn equipment shall be removed from service. The record of such inspections shall be kept in the office of the owner of the equipment and shall be open to representatives of the Department on demand.

### § 47.382. Penalty.

Any person who violates subchapter or any regulations of the Department or who interferes with the Department or its duly authorized representative in the enforcement of these provisions or regulations shall be subject to summary proceedings before an alderman, magistrate, or justice of the peace, and upon conviction shall be penalized under the provisions of section 15 of act of May 18, 1937 (P. L. 654, No. 174) (43 P. S. § 25-15).

## Subchapter K. SAFETY GLAZING MATERIAL

Sec.	
47.391.	Definitions.
47.392.	Scope.
47.393.	Removal and replacement of guards.
47.394.	Owner's responsibility.
47.395.	Employers' responsibility.
47.396.	Submission of plans for approval.
47.397.	Posting, painting or marking.
47.398.	General specifications.

### Source

The provisions of this Subchapter K adopted October 27, 1972, 2 Pa.B. 2079; amended March 29, 1974, 4 Pa.B. 580, unless otherwise noted.

### § 47.391. Definitions.

The following words and terms, when used in this subchapter, have the following meanings, unless the context clearly indicates otherwise:

*Any other glazed installation or structure*—Any portion of a building to which this subchapter applies, wherein glazing materials are used whether as doors, panels, screens, brattices, portals or aperture closures and which when subject to human impact could cause injury to persons.

*Approved*—Approved by the Industrial Board.

*Board*—The Industrial Board.

*Building*—Any structure or enclosure devoted to human occupancy in the following categories of use:

(i) *Commercial buildings*—Any structures or enclosures wherein goods or services are sold or offered or stored or wherein business is transacted whether public or private or mixed or wherein persons are housed in multiple occupancy or in which industry is conducted.

(ii) *Public buildings*—Any structures or enclosures in which persons assemble for entertainment, convention, education, instruction, worship or coming together for any purpose, whether the use is public or private or mixed.

(iii) *Residences*—Residences shall include multiple housing wherein persons reside and are domiciled and including health care facilities.

*Department*—The Department of Labor and Industry.

*Entrance door*—Any closure of an opening for passage of persons which closure may be removed in any manner sliding laterally, swinging in or out or being raised above the opening, and which may be again positioned as a closure.

*Fixed glazed panel*—A portion of a wall, interior or exterior, consisting of a frame for the support of glazing material and the glazing material itself exclusive of decorative or stain glass in buildings intended and used for purposes of religious worship which stand in the normal path of travel and upon human impact could injure the person whose motion caused the impact or other persons then nearby.

*Glass entrance door*—An entrance or exit door through which may be seen the exterior or the interior of the building in a manner which may not clearly indicate the presence of solid barrier to entrance or exit or which if struck by a person or object during passage through the door could cause injury to the persons.

*Glazing materials or glazed materials*—Any pane of glass, whether tempered, laminated, or otherwise treated and regardless of whether the pane is safety glass, and other materials which are used as glass substitutes.

*Secretary*—The Secretary of Labor and Industry.

*Shower door/tub enclosure*—The closure of a bathing shower stall or bathtub, the materials of which upon human impact could shatter so as to injure the person whose motion caused the impact.

*Sliding glass door*—The closure of an opening for passage of persons, when said closure is opened in any manner by sliding laterally across the opening and contains materials which could, upon human impact, injure the person passing through the opening.

*Storm door*—The outer closure of an exterior opening designed for the purpose of excluding inclement weather and the materials of which could upon human impact shatter so as to injure the person passing through the opening.

**Source**

The provisions of this § 47.391 amended January 26, 1979, 9 Pa.B. 314. Immediately preceding text appears at serial pages (15232) and (13470).

**§ 47.392. Scope.**

This subchapter applies to all buildings and facilities within this Commonwealth as defined and enumerated herein and in the act of June 2, 1971 (P. L. 115, No. 5) (35 P. S. § 5811).

**§ 47.393. Removal and replacement of guards.**

No person shall remove or make ineffective any safe-guard, safety appliance or device required by these regulations, except for the purpose of immediately making repairs or adjustments; and any person or persons who remove or make ineffective any safe-guard, safety appliance or device for repairs or adjustments, shall replace the same immediately upon completion of the repairs or adjustments.

**§ 47.394. Owner's responsibility.**

Every owner, lessee or person exercising direction or control over any person or persons who remove or make ineffective such safeguards, safety appliance or device shall have the safeguard, safety appliance or device so removed or made ineffective promptly and properly replaced or made effective.

**§ 47.395. Employers' responsibility.**

Every employe shall use, or cause to be used all safeguards, safety appliances or devices, furnished for his protection and shall carry out all regulations which may concern or affect his conduct.

**§ 47.396. Submission of plans for approval.**

Before any installation to which these regulations apply is made or the safety glazing material is to be installed is furnished for installation, the installation and furnishment of glazing materials shall be submitted in the form of detailed architectural plans and elevations consisting of drawings to scale for all portions of the buildings contemplated to contain such installations, to and approved by the Bureau of Occupational and Industrial Safety, Division of Building, Department of Labor and Industry. All drawings shall be submitted in triplicate.

**§ 47.397. Posting, painting or marking.**

All glazed doors or panels recited as pertinent to these regulations shall be posted, painted or marked as hereinafter stipulated including those previously

glazed with nonsafety glazing materials prior to the effective date of the act of June 2, 1971, (P.L. 115, No. 5) (35 P.S. § 5811).

**§ 47.398. General specifications.**

(a) *Buildings.* All buildings, structures or enclosures covered by this subchapter shall be designed and constructed requiring the installation of safety glazing materials which meet the requirements of ANSI Standard Z-97. 1-1966 in all openings glazed and known as glass entrance doors, sliding glass doors, storm doors, bathtub enclosures and fixed glazed panels adjacent to entrance and exit doors, whether or not such glazing is transparent, except those glazing materials used as the curved panel in revolving doors.

(b) *Labeling.* Each light of safety glazing material manufactured, distributed, imported or sold for use in hazardous locations or installed in such a location within the Commonwealth, shall be permanently labeled by the means as etching, sandblasting, firing of ceramic material on the safety glazing material or by other suitable means. The label shall identify the labeler, whether manufacturer, fabricator or installer, and the nominal thickness and the type of safety glazing material and the fact that said material meets the test requirements of USA Standard Z-97.1-1966 (now ANSI) and such further requirements as may be adopted by the Department. The label shall be legible and visible after installation.

(c) *Posting, painting or marking.* Transparent glass or plastic doors in commercial or public places in buildings open to the public, must in addition to use of safety glazing materials; be posted, painted or otherwise marked so as to alert the public as to their presence in accordance with standards, rules and regulations of the Department. The posting, painting or marking shall also be required in those places previously glazed with nonsafety glazing materials, prior to the effective date of the act of June 2, 1971 (P. L. 115, No. 5) (35 P. S. § 5811).

(d) *Violation of standards.* It shall be unlawful, for use in the Commonwealth, to knowingly sell, fabricate, assemble, glaze, include in specifications, install or consent to be installed any product commonly known as a sliding glass door, entrance door, fixed glazed panel adjacent to an entrance door which may be mistaken for means of ingress or egress, storm door, shower door, tub enclosure, or any other glazed structure for use in any hazardous locations, where said product, glazing material, or glazed structure contains any glass or glazing product other than safety glazing material.

**Source**

The provisions of this § 47.398 amended January 26, 1979, 9 Pa.B. 314. Immediately preceding text appears at serial page (15233).

[Next page is 49-1.]